

HAFCO WOODMASTER

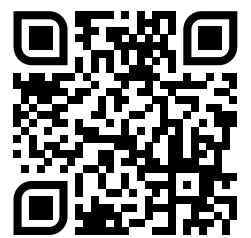

Edition : 2.0
Date: (03/26)

Instruction Manual

PANEL SAW PS-1810

Order Code: (W700)

MACHINE DETAILS

MACHINE.	PANEL SAW
MODEL NO.	PS-1810
SERIAL NO.	
DATE OF MANF.	

IMPORTED BY

AUSTRALIA



www.machineryhouse.com.au

NEW ZEALAND



www.machineryhouse.co.nz

NOTE:

This manual is only for your reference. At the time of the compiling of this manual every effort to be exact with the instructions, specifications, drawings, and photographs of the machine was taken. Owing to the continuous improvement of the HAFCO WOODMASTER machine, changes may be made at any time without obligation or notice. Please ensure the local voltage is the same as listed on the specification plate before operating any electric machine.

SAFETY SYMBOLS:

The purpose of safety symbols is to attract your attention to possible hazardous conditions



WARNING

Indicates a potentially hazardous situation causing injury or death

Indicates an alert against unsafe practices.

Note: Used to alert the user to useful information

NOTE:

In order to see the type and model of the machine, please see the specification plate. Usually found on the back of the machine. See example (Fig.1)

Fig.1

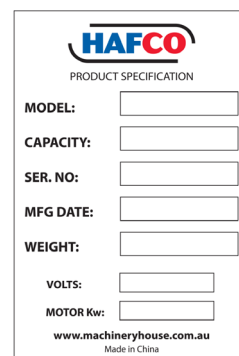

CONTENTS:

1. GENERAL MACHINE INFORMATION	
1.1 Specifications.....	4
1.2 Packing List.....	4
1.3 Identification.....	5
2. SAFETY	
2.1 General Woodworking Machine Safety.....	6
2.2 Specific Safety For Dust Collectors	8
2.3 Preventing Kickback	9
3. POWER SUPPLY	
3.1 Electrical Installation	10
3.2 Full Load Current.....	10
4. SETUP	
4.1 Unpacking	11
4.2 Clean Up	11
4.3 Site Preparation.....	11
4.4 Lifting Instructions.....	11
4.5 Assembly.....	12
Install The Extension Table.....	12
Install The Support Leg	13
Install The Rip Fence Rail.....	13
Install The Rear Support Rail	13
Install The Rear Extension Table.....	13
Install The Blade Hand Wheels	13
Fitting The Rip Fence & Align The Rail.....	14
Install The Swing Arm Assembly	14
Install The Sliding Panel Assembly	14
Adjust The Sliding Panel Level.....	15
Install The Push Handle And Lock Pin	15
Install The Cross Cut Table.....	15
Install The Cross Cut Fence.....	15
Install The Hold Down/Mitre Gauge	16
Install The Dust Port.....	16
Install The Blade Guard.....	16
Install The Dust Hose Support	16
Install Dust Hoses	16
5. OPERATION	
5.1 Operation Overview.....	17
5.2 Checking The Work Piece.....	17
5.3 Controls.....	18
5.4 Changing The Blade.....	18
5.5 Replace And Adjusting The Scoring Blade	19
5.6 Replace And Adjust The Riving Knives	20
5.7 Rip Cutting	21
5.8 Cross Cutting	22
6. MAINTENANCE	
6.1 Replacing The Scoring Belt.....	25
6.2 Replacing The Main Belt	26
6.3 Sliding Panel Parallel Adjustment	26
6.4 Wiring Diagram.....	27
6.5 Troubleshooting	28
SPARE PARTS	29

1.1 SPECIFICATIONS

Order Code	W700
Model	SP-1810
Blade Diameter (mm)	Ø315
Table Size (W x H) (mm)	820 x 800
Table Size With Extensions (mm)	1260 x 800
Max. Depth Of Cut 90° (mm)	100
Max. Depth Of Cut 45° (mm)	80
Scribe Blade Diameter (mm)	Ø90
Tilt Arbor (deg)	0 ~ 45°
Sliding Table Stroke (mm)	1900
Cross Cut with Flip Over Stop (mm)	1230 - 2280
Rip Capacity (mm)	1240
Motor Power (kW / hp)	3.0 / 4
Voltage (V)	240
Amperage (A)	15
Footprint (W x D x H) (mm)	2830 x 3960 x 1160
Weight (kg)	342

1.2 PACKING LIST

Main Crate:

- Main saw unit
- Cast iron extension table
- Steel plate extension table w/support leg
- Rear extension table w/support
- Swing arm assembly (inside main saw unit)
- Cross cut table
- Roller, cross cut
- Blade guard
- 2-1/2" dust hose
- Dust port
- Mitre gauge
- Hand wheels (2)
- Hardwares
- Tools
- 1- 3-15 mm open head wrench Arbor wrench
- Arbor pin
- 3, 4, 5, 6 mm "L" wrench
- Push stick

(Some parts are inside the main saw unit) Edge shoe

Rail crate:

- Rip fence
- Rip fence rail
- Rear support rail
- Sliding table
- Sliding table carrier
- Support leg, sliding carrier
- Cross cut fence.
- Hold down w/fence
- Flip stop

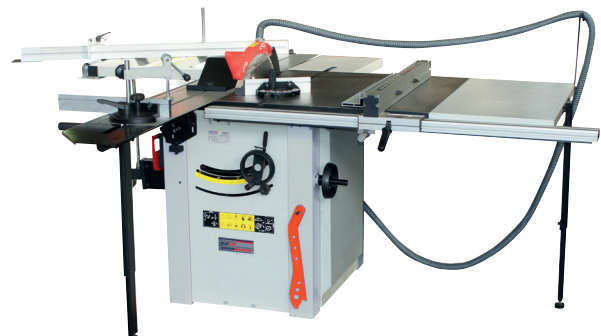

1.3 IDENTIFICATION

Become familiar with the names and locations of the controls and features shown below to better understand the instructions when mentioned later in this manual.



A	Cross Cut Table	H	Power Switch
B	Flip Stops	I	Blade Elevation Hand Wheel
C	Cross Cut Fence	J	Blade Angle Hand Wheel
D	Support Roller	K	Rip Fence
E	Sliding Panel	L	Rip Fence Lock Down Handle
F	Blade Guard	M	Rip Fence Rail
G	Rear Table	N	Support Leg

2. IMPORTANT INFORMATION

2.1 GENERAL WOODWORKING MACHINE SAFETY

DO NOT use this machine unless you have read this manual or have been instructed in the use of this machine in its safe use and operation



WARNING!

This manual provides safety instructions on the proper setup, operation, maintenance and service of this machine. Save this manual, refer to it often, and use it to instruct other operators.

Failure to read, understand and follow the instructions in this manual may result in fire or serious personal injury—including amputation, electrocution, or death.

The owner of this machine is solely responsible for its safe use. This responsibility includes, but is not limited to proper installation in a safe environment, personnel training and authorization to use, proper inspection and maintenance, manual availability and comprehension of the application of the safety devices, integrity and the use of personal protective equipment.

The manufacturer will not be held liable for injury or property damage from negligence, improper training, machine modifications or misuse.

Exposure to the dust created by power sanding, sawing, grinding, drilling and other construction activities may cause serious and permanent respiratory or other injury, including silicosis (a serious lung disease), cancer, and death. Avoid breathing the dust, and avoid prolonged contact with dust. Some examples of these chemicals are:



- Lead from lead-based paints.
- Crystalline silica from bricks, cement and other masonry products.
- Arsenic and chromium from chemically-treated timber.

Always operate tool in well ventilated area and provide for proper dust removal. Use a dust collection system along with an air filtration system whenever possible. Always use properly fitting approved respiratory protection appropriate for the dust exposure, and wash exposed areas with soap and water.



Safety glasses must be worn at all times in work areas. Earmuffs should be worn if the work area is noisy.



Sturdy footwear must be worn at all times in work areas.



Gloves should NOT be worn when operating machinery. Should only be worn when handling the material



Long and loose hair must be contained with a net or under a hat

2.1 GENERAL WOODWORKING MACHINE SAFETY Cont.

DISCONNECT POWER FIRST. If using power, always disconnect the machine from power supply before making adjustments, or servicing the machine. This prevents any risk of injury from unintended startup or contact with live wires.

WEARING PROPER APPAREL. Do not wear clothing, apparel or jewelry that can become entangled in moving parts. Always tie back or cover long hair. Wear non-slip footwear to avoid accidental slips, which could cause loss of operating control.

HEARING PROTECTION. Always wear hearing protection when operating or observing loud machinery. Extended exposure to this noise without hearing protection can cause permanent hearing loss.

REMOVE ADJUSTING TOOLS. Tools left on machinery can become dangerous projectiles upon startup. Never leave hex keys, wrenches, or any other tools on machine. Always verify removal before starting!

USE CORRECT TOOL FOR THE JOB. Only use this tool for its intended purpose. Do not force the machine or its attachments to do a job for which they were not designed. Never make unapproved modifications. Modifying the machine or using it differently than intended may result in malfunction or mechanical failure that can lead to personal injury or death!

AWKWARD POSITIONS. Keep proper footing and balance at all times when operating machine. Do not overreach! Avoid awkward hand positions that make operating control difficult. This could increase the risk of accidental injury

GUARDS & COVERS. Guards and covers reduce accidental contact with moving parts or flying debris. Make sure they are properly installed, undamaged and working correctly.

TRAINED OPERATORS ONLY. Only allow trained or supervised people to use this machine. When the machine is not being used, disconnect the power to the machine to prevent unauthorized use—especially around children. Make the workshop safe.

FORCING MACHINERY. Do not force the machine. It will do the job safer and better at the rate for which it was designed.

NEVER STAND ON MACHINE. Serious injury may occur if the machine is tipped or if the cutting tool is unintentionally contacted

STABLE MACHINE. Unexpected movement during operation greatly increases risk of injury or loss of control. Before starting, verify the machine is stable and if using a mobile base it is locked in position.

UNATTENDED OPERATION. To reduce the risk of accidental injury, turn the machine OFF and ensure all moving parts have completely stopped before walking away. Never leave the machine running while unattended.

MAINTAIN WITH CARE. Follow all the maintenance instructions and lubrication schedules to keep the machine in good working condition. A machine that is improperly maintained could malfunction, leading to serious personal injury or death.

CHECK DAMAGED PARTS. Regularly inspect the machine for any condition that may affect the safe operation. Immediately repair or replace damaged or parts that are incorrectly fitted before operating.

CHILDREN & BYSTANDERS. Keep children and bystanders at a safe distance from the work area. Stop using machine if they become a distraction.



WARNING!

Machines are safeguarded to protect the operator from injury or death with the placement of guards. Machines must not be operated with the guards removed or damaged.

2.2 SPECIFIC SAFETY FOR TABLE SAWS

DO NOT use this machine unless you have been instructed in its safe use and operation and have read and understood this manual



Safety glasses must be worn at all times in work areas



Long and loose hair must be contained.



Hearing protection must be worn



Sturdy footwear must be worn at all times in work areas



Safety Mask must be worn to eliminate possible lung damage



Rings and jewellery must not be worn.

PRE-OPERATIONAL SAFETY CHECKS

- ✓ Locate and ensure you are familiar with all machine operations and controls.
- ✓ Ensure all guards are fitted, secure and functional. Do not operate if guards are missing or faulty.
- ✓ Ensure the saw is properly secured to a work table by bolts/clamps at approximately hip height.
- ✓ Ensure the saw is operated on an RCD protected circuit.
- ✓ Check workspaces and walkways to ensure no slip/trip hazards are present.
- ✓ Keep table and work area clear of all tools, off-cut timber and sawdust.
- ✓ Start the dust extraction unit before using the machine.

OPERATIONAL SAFETY CHECKS

- ✓ Ensure all adjustments are secure before making a cut.
- ✓ Use clamps to secure and support the workpiece to a stable platform. Do not use a length stop on the free scrap end of a clamped workpiece.
- ✓ Before turning on the saw, perform a dry run of the cutting operation to ensure no problems will occur when the cut is made.
- ✓ Avoid reaching over the saw line. Do not cross arms when cutting.
- ✓ When pulling the saw down with your right hand, keep the left hand, especially the thumb, well clear of the line of cut.
- ✓ If workpiece is bowed or warped, clamp it with the outside bowed face toward the fence.
- ✓ After finishing the cut, release the switch, hold the saw arm down and wait for blade to stop before removing work or off-cut piece.
- ✓ Before making any adjustments, disconnect the plug from the power source and bring the machine to a complete standstill.

DON'T

- ✗ Do not use faulty equipment. Immediately report suspect equipment.
- ✗ Do not exceed the maximum cut for the machine.
- ✗ Do not cut more than one workpiece at a time.
- ✗ Do not start the saw with the blade touching the workpiece. Allow the blade to reach full speed first.
- ✗ Do not cut branches, dowel, or wood with embedded nails or screws.
- ✗ Do not rip solid timber along the grain.
- ✗ Do not cut ferrous or non-ferrous material.

POTENTIAL HAZARDS AND INJURIES

- Saw may grab and 'kick-back' toward operator.
- Flying chips and airborne dust.
- Contact with rotating blade.
- Eye injuries.
- Noise.

2.3 PREVENTING KICKBACK

Statistics prove that most common accidents amongst table saw users can be linked to kickback. Kickback is typically defined as the high-speed expulsion of stock from the table saw toward its operator. In addition to the danger of the operator or others in the area being struck by the flying stock, it is often the case that the operator's hands are pulled into the blade during the kickback.

Never attempt freehand cuts. If the work-piece is not fed perfectly parallel with the blade, a kickback will likely occur. Always use the rip fence or crosscut fence to support the work-piece.

Make sure the riving knife is always aligned with the blade. A misaligned riving knife can cause the workpiece to bind or stop the flow of the cut, resulting in an increased chance of kickback. If you think that your riving knife is not aligned with the blade, check it immediately!

Ensure that your table slides parallel with the blade; otherwise, the chances of kickback are increased.

Take the time to check and adjust the sliding table.

Use the riving knife during every cut. The riving knife helps maintain the kerf in the work-piece after it is cut, therefore, reducing the chance of kickback.

Feed cuts through to completion. Anytime you stop feeding a work-piece that is in the middle of a cut, the chance of binding, resulting in kickback, is greatly increased.

Protecting The Operator from Kickback:

NOTE: *Even if you know how to prevent kickback, it may still happen. Here are some tips to reduce the likelihood of injury if kickback DOES occur:*

Stand to the side of the blade during every cut. If a kickback does occur, the thrown work-piece usually travels directly in front of the blade.

Always wear safety glasses or a face shield. In the event of a kickback, your eyes and face are the most vulnerable part of your body.

Never, for any reason, place your hand behind the blade. Should kickback occur, your hand will be pulled into the blade.

Use a push stick to keep your hands farther away from the moving blade. If a kickback occurs, the push stick will most likely take the damage that your hand would have received.



WARNING!

Saw blades are sharp. Keep fingers away from the cutter edge. Take care when handling saw blades. Blades can cause deep cuts and serious injury.



WARNING!

USE A PUSH STICK to keep your hands farther away from the moving blade. If a kickback occurs, the push stick will most likely take the damage that your hand would have received.

3. POWER SUPPLY

3.1 ELECTRICAL INSTALLATION

Place the machine near an existing power source. Make sure all power cords are protected from traffic, material handling, moisture, chemicals, or other hazards. Make sure there is access to a means of disconnecting the power source. The electrical circuit must meet the requirements for 240V.

NOTE : The use of an extension cord is not recommended as it may decrease the life of electrical components on your machine.

ELECTRICAL REQUIREMENTS

Nominal Voltage.....	240V
Cycle.....	50 Hz
Phase.....	Single Phase
Power Supply Circuit.....	15 Amps
Full Load Current.....	11.3 Amps

(Full load current rating is also on the specification plate on the motor.)

3.2 FULL-LOAD CURRENT RATING

The full-load current rating is the amperage a machine draws when running at 100% of the output power. Where machines have more than one motor, the full load current is the amperage drawn by the largest motor or a total of all the motors and electrical devices that might operate at one time during normal operations.

Full-Load Current Rating for these machine is available on the motor plate.

It should be noted that the full-load current is not the maximum amount of amps that the machine will draw. If the machine is overloaded, it will draw additional amps beyond the full-load rating and if the machine is overloaded for a long period of time, damage, overheating, or fire may be caused to the motor and circuitry.

This is especially true if connected to an undersized circuit or a long extension lead. To reduce the risk of these hazards, avoid overloading the machine during operation and make sure it is connected to a power supply circuit that meets the requirements.



4 SET-UP

4.1 UNPACKING

This machine was carefully packaged for safe transport. When unpacking, separate all enclosed items from packaging materials and inspect them for shipping damage. If items are damaged, please contact your distributor.

NOTE: Save all the packaging materials until you are completely satisfied with the machine and have resolved any issues with the distributor, or the shipping agent.

When unpacking, check the packing list to make sure that all parts shown are included. If any parts are missing or broken, please contact your distributor.

4.2 CLEAN - UP

The unpainted surfaces of the machine have been coated with a waxy oil to protect them from corrosion during shipment. Remove the protective coating with a solvent cleaner or a citrus based degreaser.

Optimum performance from your machine will be achieved when you clean all moving parts or sliding contact surfaces that are coated with rust preventive products.

It is advised to avoid chlorine based solvents, such as acetone or brake parts cleaner, as they will damage painted surfaces and strip metal should they come in contact. Always follow the manufacturer's instructions when using any type of cleaning product.

4.3 SITE PREPARATION

Working clearances can be thought of as the distances between machines and obstacles that allow safe operation of every machine without limitation. Consider existing and anticipated machine needs, size of material to be processed through each machine, and space for auxiliary stands and/or work tables. Also consider the relative position of each machine to one another for efficient material handling. Be sure to allow yourself sufficient room to safely run your machines in any foreseeable operation.

Consider existing and anticipated needs, size of material to be processed through each machine, and space for auxiliary stands, work tables or other machinery when establishing a location for your saw. See Fig. 4.1 for the maximum working clearances of the Sliding Panel Saw.

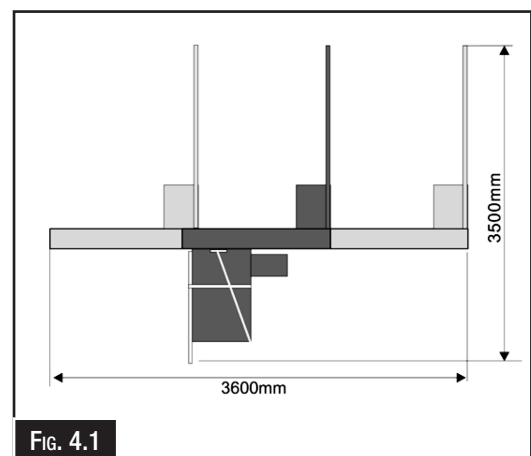

4.4 LIFTING INSTRUCTIONS



WARNING

This machine is extremely heavy. Serious personal injury may occur if safe moving methods are not followed. To be safe, you will need assistance and power equipment when moving the shipping crate and removing the machine from the crate.



On the day that the machine arrives, make sure that a forklift or lifting device, with sufficient capacity is available to unload the machine from the vehicle. Ensure access to the chosen site is clear and that doors and ceilings are sufficiently high and wide enough to receive the machine.

4.5 ASSEMBLY

The machine must be fully assembled before it can be operated. First clean any parts that are coated in rust preventative to ensure the assembly process can proceed smoothly.

Warning!

Use lifting straps with a minimum of 500 kgs lifting capacity. If the lifting strap breaks, serious personal injury may occur.

1. Remove the top of crate and position the forklift forks together and directly above the saw.
2. Place four lift rings onto Saw Base Unit and place two lifting straps over the forks and attach the lifting rings
3. Insert a wood block for protecting the main switch. (Fig. 4.2)
4. Lift the saw base unit and move it to your predetermined location.
5. Before lowering the saw into position, place four rubber blocks under the frame.
6. Lower the saw on the floor.



FIG. 4.2

Install the extension table

Take out the cast iron extension table, steel plate extension table and rear extension table from the Saw Base Unit crate.

Warning!

The cast iron extension table is a heavy part that weighs over 35 kgs. To be safe, you will need assistance

1. Attach the Cast iron extension table to the major table.

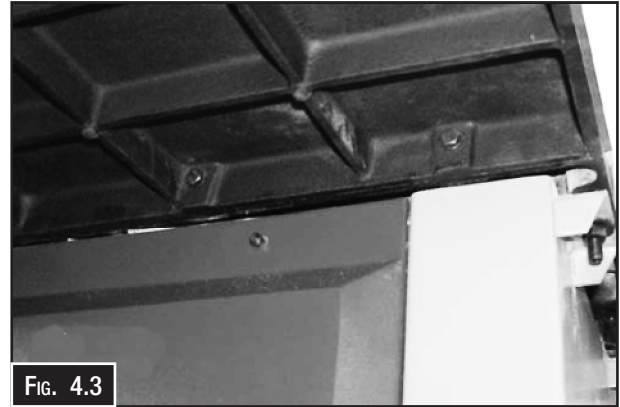

FIG. 4.3

2. Center the extension table over the edges and tap it. Check the surface alignment.

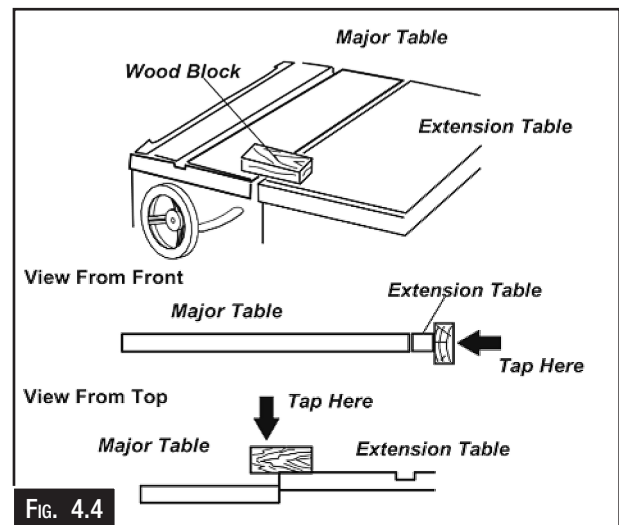

FIG. 4.4

3. Tighten 4-screws with 13 mm spanner. **Attach the steel plate extension table to cast iron extension table, Align and tighten them as "install the cast iron extension table".**



FIG. 4.5

4.5 ASSEMBLY Cont.

Install The Support Leg: (Fig. 4.6)

1. Attach the support leg to steel plate extension table with 2-M8x20 Hex head screws, washers and nuts and tighten them.
2. Adjust the support leg to ensure the steel plate extension table is at the same level with the cast iron extension table.

Install The Rip Fence Rail: (Fig. 4.7)

1. Place 5-M8x25 square head screws, washers and hex nuts onto major table and the extension tables (washers and nuts inside table). The nuts only need to be turned a few turns so there is an adequate gap to fit the rip fence rail.
2. Remove the left end cap of rip fence rail. Slide the slot on the rip fence rail over the 5-bolts. Adjust each bolt to fit the rail closely to table.
3. Push the rail against the tables and hand tighten each hex nut. The rail will need further adjustment.
4. Put the left end cap onto the rail, and tighten it with tapping screws.

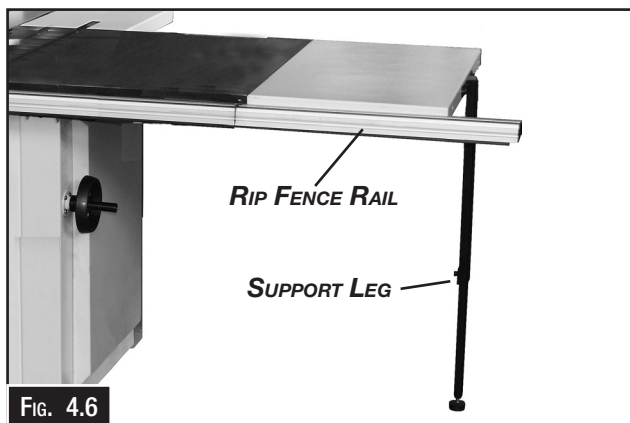

Install The Rear Support Rail: (Fig. 4.8)

Attach the rear support rail onto the cast iron and steel plate extension tables, with 4-M8x25 square head screws, washers and nuts, tighten them.

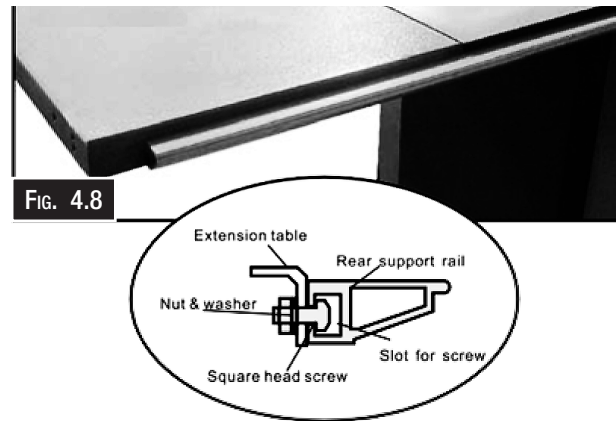

Install The Rear Extension Table (Fig. 4.9)

1. Attach the rear extension table to the rear portion of major table with 2-M8x16 hex head screws, washers and hex nuts.
2. Place the bracket onto rear panel of saw base unit with a M8x16 hex head screw, and the other end of bracket mounted to rear extension table with a M8x16 hex head screw.
3. Align the rear extension 0.5mm lower than the major table.



Install The Blade Hand wheels (Fig. 4.10)

1. Fitting the elevation hand wheel and angle hand wheel onto the elevation and angle shafts.



Fitting The Rip Fence & Align The Rail (Fig. 4.11)

1. Move the blade tilt to 0° (blade 90° to table), and raise the main blade all the way up.
2. Fit the profile of the rip fence carrier into the opposite profile on the rip fence rail.
3. Slide the rip fence to touch the main blade.
4. Tap the right end of rip fence rail to ensure the “O” scale on rail is aligned with the red line on lens of rip fence carrier.

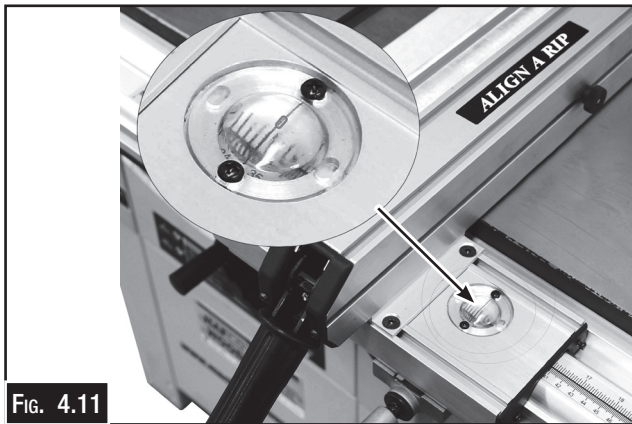

FIG. 4.11

Install The Swing Arm Assembly: (Fig. 4.12)

1. Place 4 M8x30 hex head screws to mount the swing arm assembly to the saw base unit, and keep the arm on horizontal level.

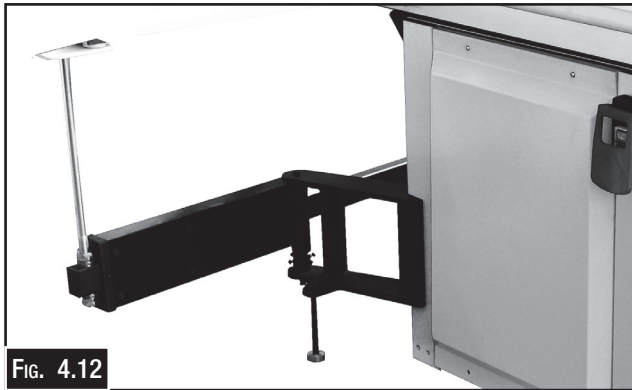

FIG. 4.12

2. Set up table as shown in Fig.4.13, 14. On the RH side of table the slide assembly is to be 540mm from the RH side of machine Base.

This will avoid swing arm hitting the support leg and will give you optimal cutting lengths.

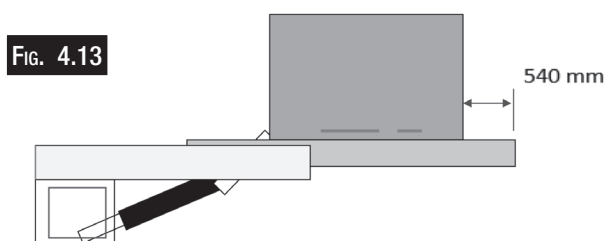

FIG. 4.13

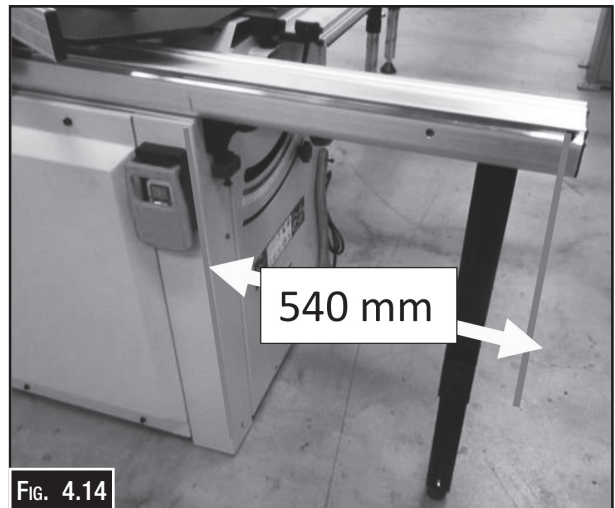

FIG. 4.14

Install The Sliding Panel Assembly:

On assembly of the sliding table to the machine, note the position of the thin steel plate. It goes between the bottom of the sliding table & the top of the black attachment bracket. (Fig. 4.15)

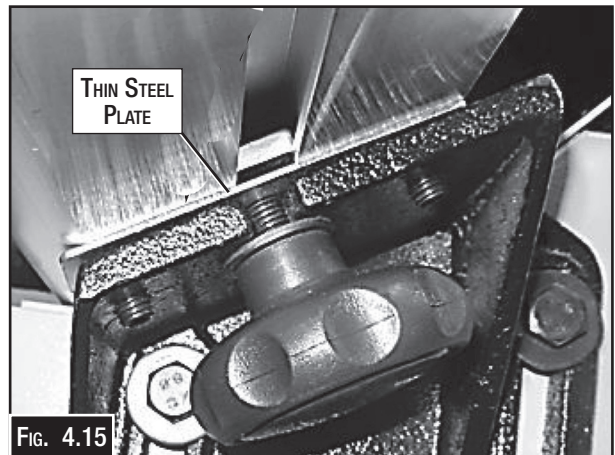

FIG. 4.15

1. Place 2 sets of star-type screws (include 8mm washer, insert, screw guide) into the lower slot of sliding panel carrier. (Fig. 4.16)



FIG. 4.16

2. Put the sliding panel assembly onto the sliding panel supports, and lay two star-type screws. (Fig. 4.16)

- Put the sliding panel assembly onto the sliding panel supports, and attach the two star-type screws. (Fig. 4.17)

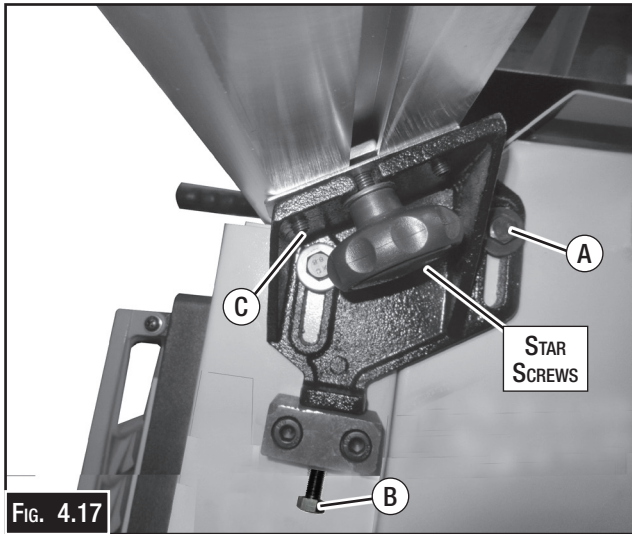

Adjust The Sliding Panel Level:

- Place a level rule (cross cut fence) on to major table and sliding panel.
- Loosen 4-M8x25 hex screws (A), adjust the M8x40 hex screw (B) to adjust the sliding panel level (Fig. 4.17).
- Then re-tighten 4-M8x25 hex screws (A).
- To fine adjust, using 3mm "L" wrench to adjust 4- M8x12 set screws(C).

Now is the point in the assembly process to make the sliding panel parallel (See Sliding Panel Parallel Adjustment Page 27)

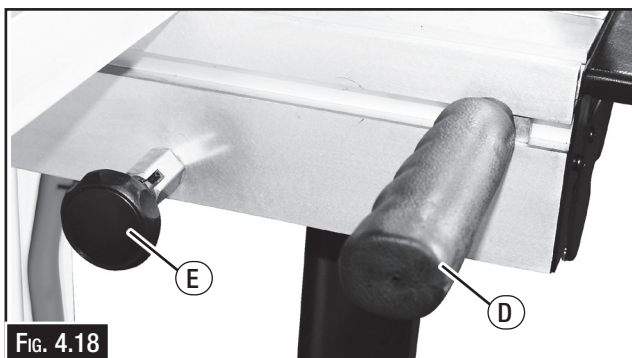

Install The Push Handle And Lock Pin:

- Slide the M12x1.75T square nut into the sliding panel and screw in the push handle (D) with a 17 mm open end wrench.
- Insert the star-type lock pin (E) into sliding panel. and lock the M10 hex nut on the opposite side.

Install The Cross Cut Table:

- Slide two M8x70 carriage bolts with T-blocks into the side slot of the sliding panel. Attach the crosscut table to the sliding panel.
- Using 2 wing nuts, mount the cross cut table to the sliding panel.
- Use 2 M6x30 Hex head screws to mount the cross cut table to the support (B). (Fig.4.19)
- Adjust 4-M12 thin hex nut (C) to adjust the cross cut table on the line with sliding panel.
- Then tighten 4-M 12 thin nut (C). (Fig. 4.19)

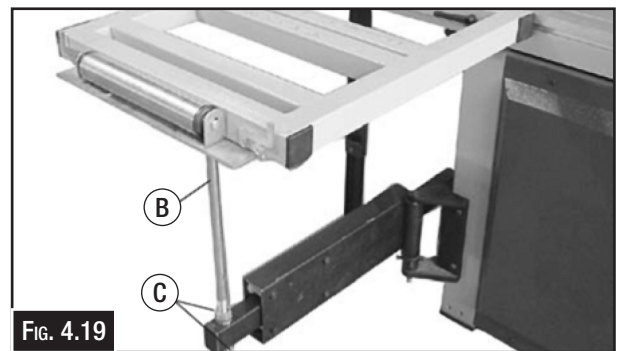

Install The Cross Cut Fence:

- Drop the cross cut fence into the forward or rear guide pin hole. Tighten the knurled nut.
- Turn the "Z" lock plate to quickly align the fence to table.
- Turn the star type screw and clamp the fence in position.
- Slide the flip stop (D) into the fence.
- Place a T-nut into the top slot of the fence, thread the stud of the hold-down clamp on to the fence.
- Attach the hold down arm onto the stud (E).

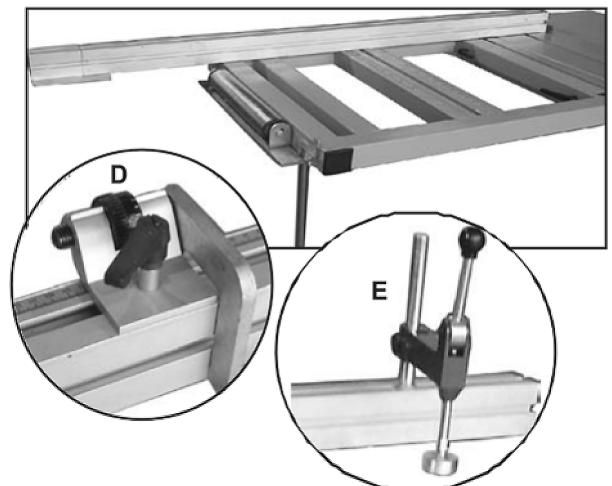

Install The Hold Down/Mitre Gauge:

1. Slide the hold down mitre Gauge onto the sliding table. Lock the hold down mitre gauge on the table with the star-type lock handle (A).
2. Aligned the Mitre Gauge fence on it.

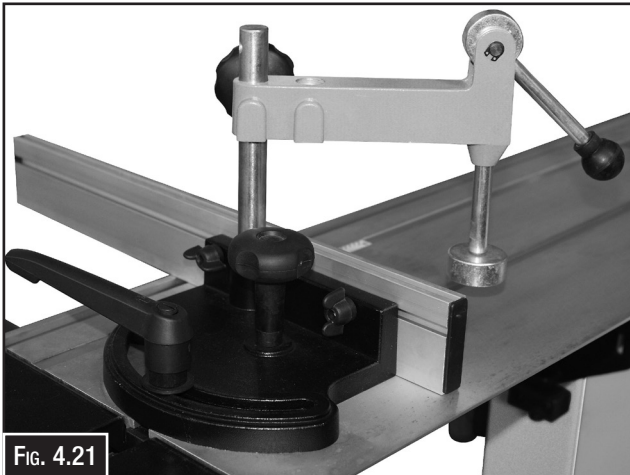

Install The Blade Guard:

The riving knife has 3 slots for different blade sizes. If using the 254 mm blade place the blade guard onto 254 slot; if using the 305 or 315 mm place the blade onto 315 slot.

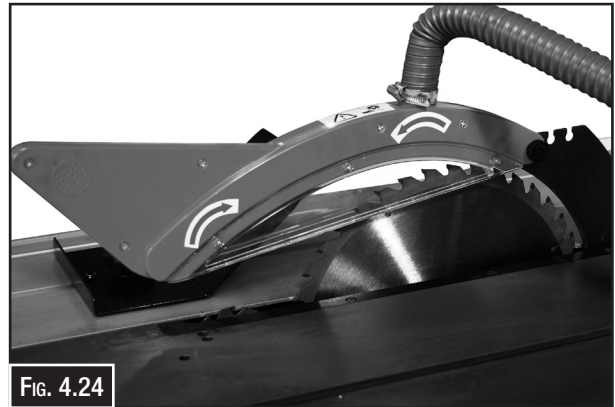

Install The Dust Port:

Place the dust port onto the bottom of rear panel,(Fig. 4.22) fixing it with 4 off M6x 12 pan head screws washers and nuts (nuts inside stand).

With Hose clamps supplied, fit the 4" hose supplied (Fig. 4.23) on the inside of machine from the dust port of the lower blade guard to the 100mm dust port now in the base of stand .

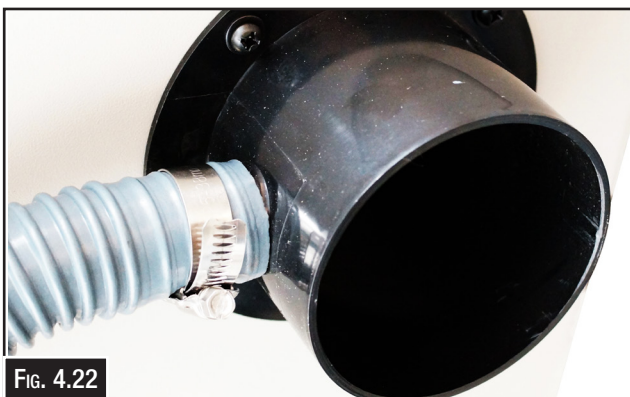

Install The Dust Hose Support:

Install the dust hose support onto the rear portion of steel plate extension table with 2off M6x20 hex head screws washers and nuts (nuts under the table). (Fig. 4.25)

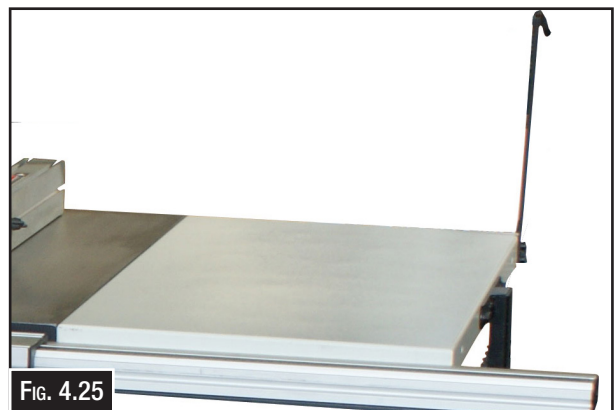

Install Dust Hoses:

1. Install the 2" dust hose onto the blade guard with 2" hose clamp.(Fig. 4.24)
2. Put the 2" dust hose onto dust hose support, keep free with the working table.(Fig. 4.25)
3. Another end of 2" dust hose clamps to the main dust port on the bottom of rear panel. (Fig. 4.22)
4. Install 4" dust hose (not Supplied) to dust collector (not Supplied) to main dust port.

5. OPERATION

This machine may perform many types of operations that are beyond the scope of this manual. Many of these operations may be dangerous or deadly if performed incorrectly.

The instructions in this section are written with the understanding that the operator has the necessary knowledge and skills to operate this machine. If at any time you are experiencing difficulties performing any operation, stop using the machine!

If you are an inexperienced operator, we strongly recommend that you read books, trade articles, or seek training from an experienced operator before performing any unfamiliar operations. **Above all, your safety should come first!**

5.1 OPERATION OVERVIEW

This overview purpose is to provide a novice machine operator with a basic understanding of how the machine is used during operation, so that if the machine controls or components are mentioned later in this manual, it will be easy to understand. The overview is not intended to be an instructional guide but is only generic in nature.

Typical operation is as follows

1. Examine the workpiece to make sure it is suitable for cutting.
2. If necessary adjust the blade tilt to the desired angle of the cut.
3. Adjust the blade height so that it is approximately 6mm higher than the thickness of the work piece.
4. Set the fence to the required width of cut, and then lock it in place.
5. Check the out-feed side of the machine, that it has proper support and make sure the workpiece can safely pass all the way past the blade without interference.
6. Put on safety glasses, respirator, and hearing protection, and use the push stick if needed.
7. Start the dust collector, then the saw.
8. Feed the workpiece through the blade while maintaining a firm pressure on the workpiece against the table and fence, and keeping hands and fingers out of the cutting area.
9. Stop the machine immediately after the cut is complete.

5.2 CHECKING THE WORK PIECE

Before cutting, inspect all workpieces for the following:

- **Material Type:** This machine is intended for cutting natural and man-made wood products, laminate-covered wood products, and some plastics. Cutting drywall creates extremely fine dust and may reduce the life of the bearings.

This machine is NOT designed to cut metal, glass, stone, tile, etc. cutting these materials with a table saw may lead to injury.

- **Foreign Objects:** Nails, staples, dirt, rocks and other foreign objects are often embedded in wood. While cutting, these objects can become dislodged and be a danger to the operator or people nearby. They can also cause kickback, or cause the blade to break and fly apart. Always visually inspect your workpiece for these items. If they can't be removed, DO NOT cut the workpiece.
- **Excessive Warping:** Timber with excessive cupping, bowing, or twisting is dangerous to cut as it is unstable and unpredictable when being cut. DO NOT use workpieces with these characteristics!
- **Minor Warping:** Timber with slight cupping can be safely supported if the cupped side is facing down on the table or the fence. Timber supported on the bowed side will rock during a cut and could cause kickback or severe injury.

5.3 CONTROLS

The purpose of this control overview is to provide the novice machine operator with a basic understanding of how the machine is used during operation, and the machine controls and what they do. It also helps the operator to understand if they are discussed later in this manual.

NOTE: DO NOT start the machine until all of the setup instructions have been performed. Operating a machine that is not setup may result in malfunction or unexpected results that can lead to serious injury, death or damage to the machine or property.

ON/OFF Switch

The switch is fitted with a red door with ON/OFF buttons beneath it.

Release by pressing against the catch (Fig.5.1) to reveal the green ON and red OFF buttons.

In an emergency the red door can be pressed by any part of the body and the machine will stop. The machine cannot be started until the door is opened and the buttons exposed.



FIG. 5.1

- A. **Tilt Lock Knob:** Needs to be released before attempting to tilt the saw blade and tightened when the tilt has been set.
- B. **Height Handle:** Is used for rise and fall of the saw blade.
- C. **Height Handle Lock:** This lock handle is spring loaded and must be pushed down before the saw blade height handle can be adjusted.
- D. **Tilt Lock Scale:** Displays the amount of angle the blade has been tilted.
- E. **Tilt Adjustment Handle:** Is used to tilt the saw blade after the Tilt Lock has been released.

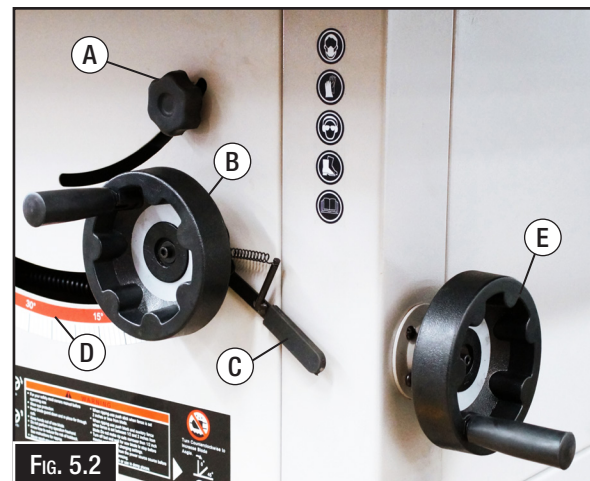

FIG. 5.2

5.4 CHANGING THE BLADE

NOTE: Any time there is a change of blade thickness, the appropriate sized riving knife and scoring blade must also be changed to match the size of main blade installed.

To Change Main Blade:

1. **DISCONNECT THE MACHINE FROM THE POWER SUPPLY**
2. Move the blade tilt to 0° (Blade 90° to table) on the control panel and raise the blade as far as it will go.
3. Move the sliding panel all the way to the right and remove two M6x12 pan head screws to expose the internal blade guard that covers the blades and riving knife.
4. Remove the blade guard from the riving knife to expose the mounting assembly.
5. Remove the table insert.
6. Insert the arbor pin into the hole on blade inner flange and locks the blade. (Fig. 5.3)

5.4 CHANGING THE BLADE Cont.

7. Using the arbor wrench, remove the arbor nut that secures the main blade (turn clockwise to loosen).
8. Remove the arbor flange and the old main blade.
9. Install the new main blade, replace the arbor flange and nut, and tighten the arbor nut to secure the main blade.



CAUTION *If the blade diameter size is changed during this procedure, now is the time to adjust the riving knife.*

If the blade thickness is different from your old blade, the scoring blade and riving knife thickness must match the new main blade.

10. Make sure the correct size riving knife is installed and aligned with the blade.
11. Move the internal blade guard back into its original position, next to the blades, and center the sliding panel.
12. Align the scoring blade to the main blade



CAUTION!

Before attempting this feature, disconnect the machine from the power supply to avoid injury to the operator from accidental startup, injury or death to the operator.

5.5 REPLACE AND ADJUSTING THE SCORING BLADE:



CAUTION *A Tapered Scoring Blade, 90 x 20 x 3mm (outer diameter core diameter, thickness) is suitable for the machine.*

1. DISCONNECT THE MACHINE FROM THE POWER
2. Move the blade tilt to 0° (Blade 90° to table) on the control panel and raise the blade as far as it will go.
3. Move the sliding panel all the way to the left and remove two M6x12 pan head screws to expose the internal blade guard that covers the blades and riving knife.
4. Remove the blade guard from the riving knife to expose the mounting assembly and remove the table insert.
5. Insert the arbor pin into the hole on blade inner flange and locks the blade. (Fig. 5.4)
6. Using the arbor wrench, remove the arbor nut that secures the main blade (turn anti-clockwise to loosen).
7. Remove the arbor flange and the old scoring blade.
8. Install the new scoring blade, replace the arbor flange and nut, and tighten the arbor nut to secure the scoring blade.

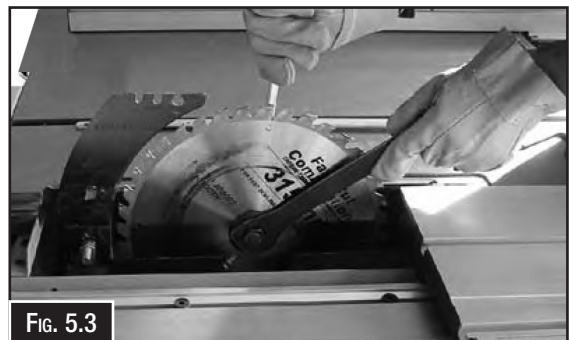

FIG. 5.3



FIG. 5.4

To Align The Scoring Blade: (Fig. 5.5)

DISCONNECT THE MACHINE FROM THE POWER.

Loosen the clamping screw (A). Lateral adjustment is made via adjusting screw (B). The height setting is made via setting screw (C). Re-tighten the clamping screw (A).

Adjust the scoring blade laterally so it is in line with the main saw-blade

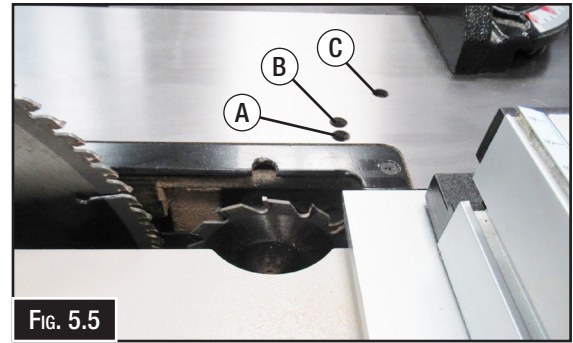

Fig. 5.5



WARNING!

Always disconnect the power to the machine before doing any adjusting or maintenance to the machine.

5.6 REPLACE AND ADJUST THE RIVING KNIVES

1. Move the blade tilt to 0° (Blade 90° to table) on the control panel and raise the blade as far as it will go.
2. Move the sliding panel all the way to the right and remove two M6x12 pan head screws to expose the internal blade guard that covers the blades and riving knife.
3. Remove the blade guard from the riving knife to expose the mounting assembly.
4. Remove the center bolt in the mounting assembly to remove the mounting plate.
5. Remove the currently installed riving knife and install the correct riving knife. (Fig. 5.6)
6. Replace the mounting plate and thread in the center bolt without completely tightening it.
7. Position the riving knife about 3mm to 8mm away from the nearest carbide tooth on the main blade.

Note: For a quick gauge, use the 3mm hex wrench to find the correct spacing between the blade and the riving knife.

8. Tighten the center bolt to secure the riving knife in position.
9. Move the internal blade guard (from step 4) back to its original position, and move the sliding panel back to center.

NOTE: The riving knife is marked with different blade size, just put the marked line under table. The center carriage bolt is mounted in a horizontal slot, so the riving knife can move far or near the main blade.



WARNING!

Blades are very sharp. If not careful, serious injury can result from touching the blades with bare hands. Leather work gloves are an option when handling these blades.

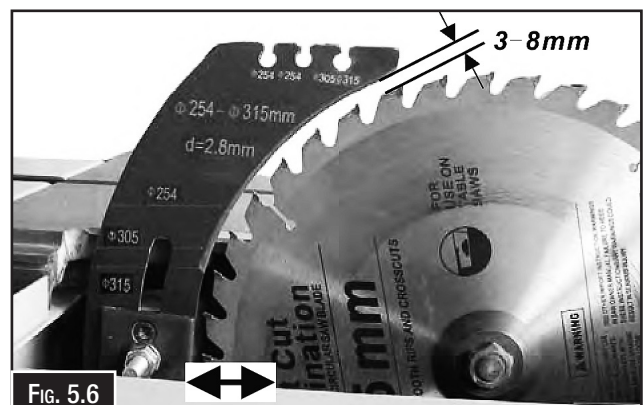

Fig. 5.6

5.7 RIP CUTTING

The sliding panel saw has the capability of rip cutting full size panels. The sliding panel removes the burden of sliding a large and heavy panel over a stationary table surface. (Fig. 5.7)

This saw also has the capability of rip cutting smaller boards, using the machine as a traditional table saw. Smaller, lighter boards are easier to slide across the stationary cast iron table surface to the right of the saw blade.

Determine which cutting operation will be best suited for the workpiece to be ripped.

To use the sliding table, read the instructions titled "Rip cutting with the sliding panel."

To use the machine as a traditional table saw, skip ahead to "Rip cutting using the traditional table saw technique."

Rip Cutting With The Sliding Panel: (Fig. 5.9)

1. Mount the crosscut table to the sliding panel.
2. Slide and secure the crosscut table to the end of the sliding table opposite the sliding table handle.
3. Install the crosscut fence in the guide pin holes and lock it in place with the knurled nut.

Note: First, drop the crosscut fence into the forward guide pin hole, turn the "Z"lock plate to align the fence. then tighten the knurled nut.

4. Set either flip stop to the desired width-of-cut.
5. Load the workpiece onto the table saw.
6. Mount the hold down arm onto the stud and lock the work-piece in place.
7. Once all the necessary safety precautions have been taken, perform the cutting operation.

Rip Cutting Using The Traditional Table Saw Technique:

1. Slide the crosscut table out of the way.
2. Lock the sliding panel into a stationary position.
3. Position the rip fence to the desired width-of-cut.
4. Once all the necessary safety precautions have been taken, load the workpiece onto the table saw and perform the cutting operation.

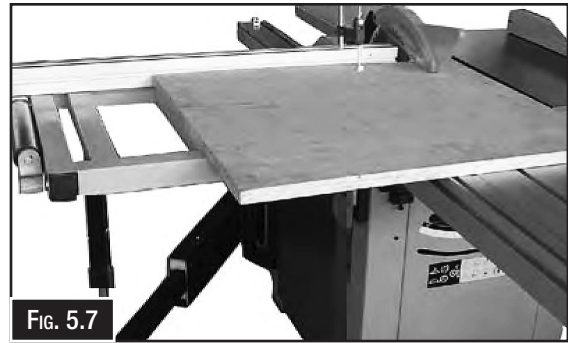

FIG. 5.7



FIG. 5.8



FIG. 5.9



WARNING!

Saw blades are sharp. Keep fingers away from the cutter edge. Take care when handling saw blades. Blades can cause deep cuts and serious injury.

5.8 CROSS CUTTING

With the crosscut fence mounted in the forward position, the sliding panel saw has the capability of crosscutting full size panels. (Fig. 5.10)

With the crosscut fence mounted in the rear position, this machine also has the capability of crosscutting smaller panels.

This machine has the capability of crosscutting workpieces while using the hold down w/mitre gauge.

Lastly, this machine has the capability of crosscutting workpieces while using the rip fence as a cut-off gauge.

Determine which cutting operation will be best suited for the workpiece to be crosscut.

If you will be crosscutting full size panels, then skip ahead to “Crosscutting full size panels.”

If you will be crosscutting smaller panels, then skip ahead to “Crosscutting smaller panels.”

If you will be crosscutting workpieces using the hold down, then skip ahead to “Crosscutting using the hold down w/mitre gauge.” (Fig. 5.12)

If you will be crosscutting workpieces using the rip fence as a cut-off gauge, then skip ahead to “Crosscutting using the rip fence as a cut-off gauge.”

Crosscutting Full Size Panels:

1. Mount the crosscut table to the sliding panel.
2. Install the crosscut fence in the forward guide pin holes and lock it in place.

Note First. drop the crosscut fence into the forward guide pin hole, turn the “Z”lock plate to align the fence. then tighten the knurled nut.

3. Set either flip stop to the desired width-of-cut.

Note If the workpiece extends to the left of the saw blade more than 1200mm. then the crosscut fence slide needs to be extended.

4. Load the workpiece onto the table saw.
5. Mount the hold down arm onto the stud and lock the work-piece in place.
6. Once all the necessary safety precautions have been taken, perform the cutting operation.

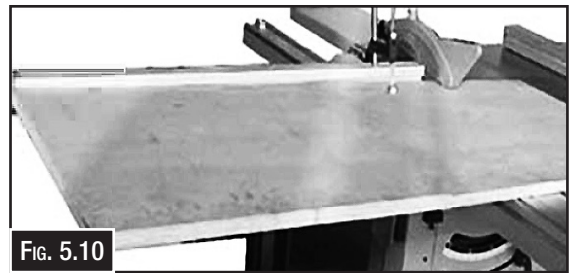

Fig. 5.10



Fig. 5.11

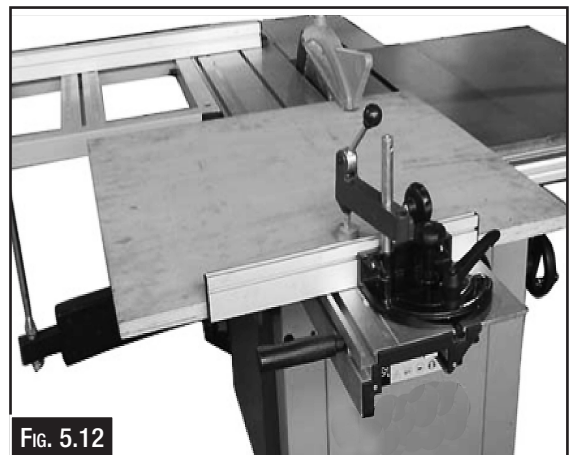

Fig. 5.12

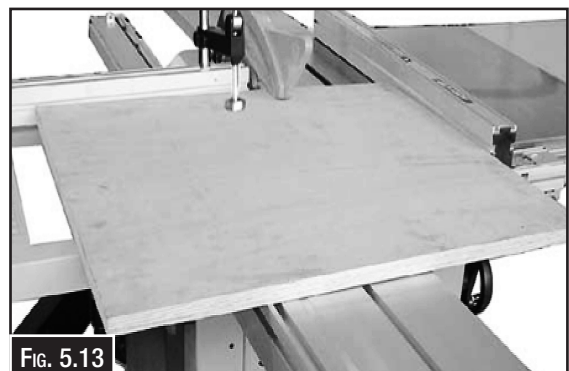

Fig. 5.13

5.8 CROSS CUTTING Cont.

Crosscutting Using The Hold Down:

1. Mount the hold down onto the sliding panel.
2. Load the workpiece onto the table saw. Secure it using the clamp.
3. Once all the necessary safety precautions have been taken, perform the cutting operation.

Crosscutting Using The Rip Fence As A Cut-Off Gauge:

1. Mount the crosscut table to the sliding panel.
2. Install the crosscut fence in the rear guide pin holes and lock it in place. Note drop the crosscut fence into the rear guide pin hole, turn the “Z”lock plate to align the fence, then tighten the knurled nut.
3. Position the rip fence to the desired width-of-cut.
4. Load the workpiece onto the table saw.
5. Mount the hold down arm onto the stud and lock the work-piece in place.
6. Once all the necessary safety precautions have been taken, perform the cutting operation.

Miter Cutting:

The cross cut table has two built-in scales for forward and rear mount fences to perform mitre cuts. (Fig.5.14)

Also the sliding panel has a built in scale for hold down clamp to perform mitre cuts.

Lastly, the machine has the capacity for mitre cutting work-pieces using the mitre gauge.

To Perform A Miter Cut Using The Cross Cut Fence:

1. Mount the cross cut fence onto the cross cut table.
2. Position the cross cut fence at the desired angle and use the ratchet lever to lock the cross cut fence in position.
3. Position the flip stop according to the length of the workpiece you want to cut off to the left of the blade.

Note If the workpiece extends to the left of the saw blade more than 1200mm, then the crosscut fence slide needs to be extended.

4. Load the workpiece onto the table saw.
5. Mount the hold down arm onto the stud and lock the work-piece in place. (Fig. 5.15)
6. Once all the necessary safety precautions have been taken, perform the cutting operation.



Fig. 5.14

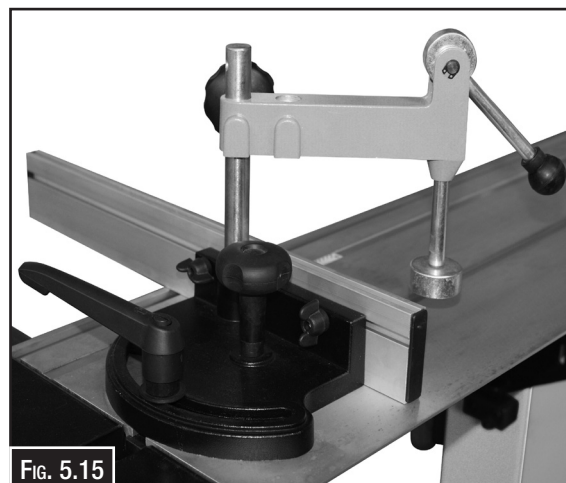
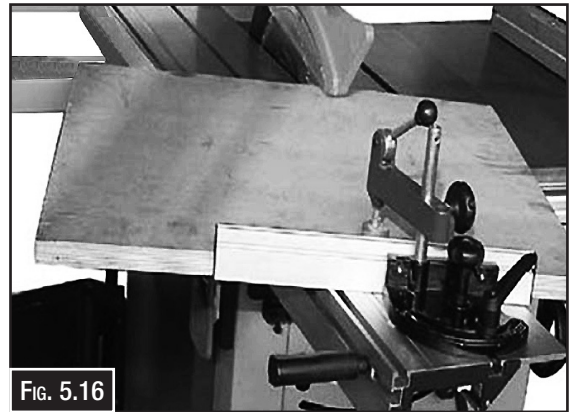

Fig. 5.15

Miter Cutting:

A Miter Cut Using The Hold Down W/Mitre Gauge:

1. Mount the hold down onto the sliding panel and fit a cut fence.
2. Position the hold down clamp w/mitre gauge at the desired angle and use the ratchet lever to lock the mitre gauge in position.
3. Load the workpiece onto the sliding panel. Secure the workpiece with the clamp.
4. Once all the necessary safety precautions have been taken, perform the cutting operation.



6. MAINTENANCE

Cleaning

Cleaning the sliding panel saw is relatively easy. Vacuum excess wood chips and sawdust, and wipe off the remaining dust with a dry cloth. If any resin has built up, use a resin dissolving cleaner to remove it. Treat all cast iron and unpainted steel with a non-staining lubricant after cleaning.

Once A Week:

- Clean sliding panel surface and grooves.
- Clean the cast iron or steel plate saw table.
- Clean the roller guide ways for the sliding table.
- Clean the aluminum rip fence and sliding grooves.
- Clean the rip fence bracket.

Once A Month:

- Vacuum inside the motor cabinet.

V-Belts

To ensure optimum power transmission from the motor to the blade and to the hydraulic pump, the V-belts must be in good condition (free from cracks, fraying and wear) and operate under proper tension. Check the V-belts at least every 3 months; more often if the saw is used daily. Replace the belts, if needed.

Bearings

The bearings are sealed and pre-lubricated and require no lubrication during their usable life. However, the saw components will operate at their best if the bearing surfaces are kept clean. This is especially important for the trunnion bearings.



WARNING!

Disconnect all power from the machine before servicing. There may be multiple power sources present. Remove the plug from the power point or remove the fuse if hardwired. Failure to do so may cause death or injury.

Main switch

The machine is equipped with a knee touch no-volt release main switch and a limit switch.

The main switch is equipped with a large size touch panel. When performing cutting work, if any part of the operators body touches the switch panel, the saw will be brought to a stop. (Fig. 5.17)

Micro switch

The limit switch is mounted under the inner guard. If you make scoring blade or main blade replacement, or remove the inner guards, the micro switch moves to the "off" position. This prevents the risk of unintentional starting.

Thermo Cut-Out:

There is thermo cut-out inside the motor. This device protects the motor from being damaged in high temperature conditions. When the motor's temperature is too high the fuse will shut off automatically. Before restarting the machine, you should check the reasons that caused the high temperature. This may need to be carried out by a qualified specialists. The thermo cutout will return to normal operation automatically once the temperature has been reduced.



FIG. 6.1

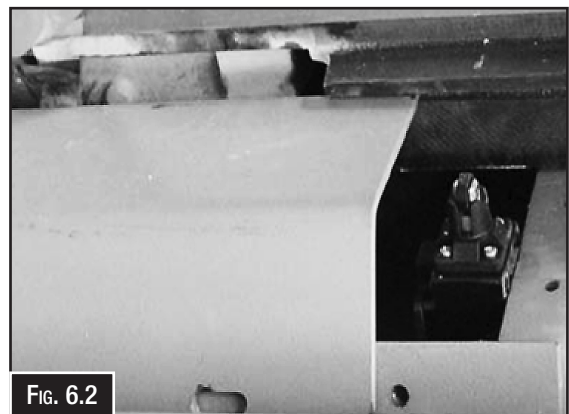

FIG. 6.2

6.1 REPLACING THE SCORING BELT

1. DISCONNECT THE SAW FROM THE POWER SOURCE!
2. Move the blade tilt to 0° (Blade 90° to table) on the control panel and lower the blade as far as it will go.
3. Remove the 4 Allen screws on the top and bottom of the right panel, and remove the left panel.
4. Push the tension pulley as far as it will go as the arrow shows. (Fig. 6.3)
5. Remove the old belt and replace new belt.
6. Re-mount the right panel.

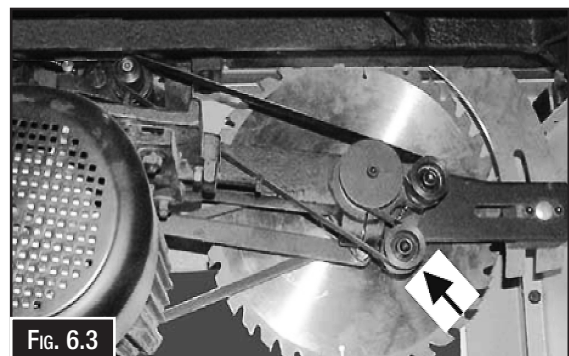

FIG. 6.3



CAUTION!

Before attempting this feature, disconnect the machine from the power supply to avoid injury to the operator from accidental startup or damage to the machine.

6.2 REPLACING THE MAIN BELT

1. DISCONNECT MACHINE FROM POWER
2. Move blade tilt to 0° (Blade 90° to table) on the control panel & raise the blade as far as it will go.
3. Move the sliding panel all the way to the left and remove two M6x12 pan head screws to expose the internal blade guard that covers the blades and riving knife.
4. Remove the blade guard from the riving knife to expose the mounting assembly. (Fig. 6.4)
5. Remove the main blade.
6. Remove 3 M8x18 Allen screw and remove the chip house.

Note To remove lower 2-M8x18 Allen screws, the main blade angle system tilt to 30°, to remove the upper 1-M8x18 Allen screw, the main blade angle system tilt to 0°.

7. Remove the 4 Allen screws on the top and bottom of left panel, and remove the left panel.
8. Loosen motor mounting 4-M8x40 hex head screws (A) & loosen the tension bolt (B). (Fig. 6.5)
9. Remove the V-belt.
10. Replace with new V-belt, tighten motor bolts and the tension bolt, close the left panel, and re-mount blade inner guard, blade, and blade guard.

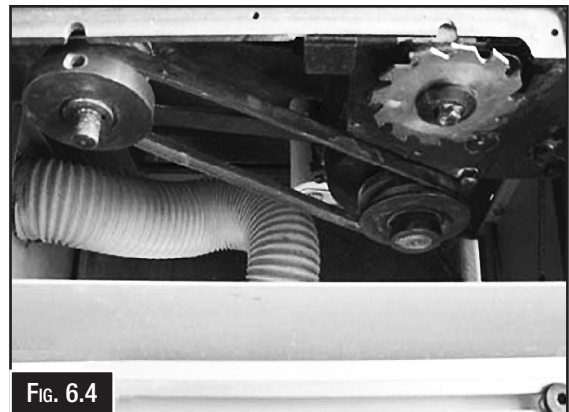

FIG. 6.4

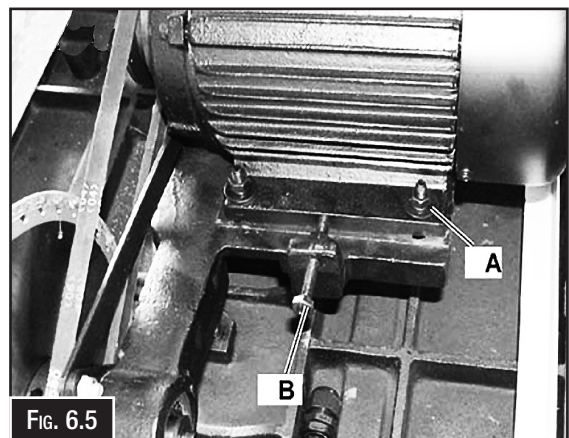

FIG. 6.5

6.3 SLIDING PANEL PARALLEL ADJUSTMENT

Now is the point in the assembly process to make the sliding panel parallel with the main saw blade and secure the sliding panel to the saw base.

Besides the tools included with the saw, this procedure requires you to have a precision ruler, a felt tip pen, and the assistance of another person.

To Adjust The Sliding Panel Parallel With The Main Blade:

1. DISCONNECT MACHINE FROM POWER
2. Set the blade to 0° on the control panel (90° with the cast iron table).
3. Raise the main blade up as far as it will go.
4. Mark the center of the blade with a felt tip pen. This will allow you to take your measurements from the exact same place on the blade.
5. Move the sliding panel all the way to one end, and using a precision ruler, measure the gap between the edge of the panel and your mark on the blade as shown in Fig. 6.6.

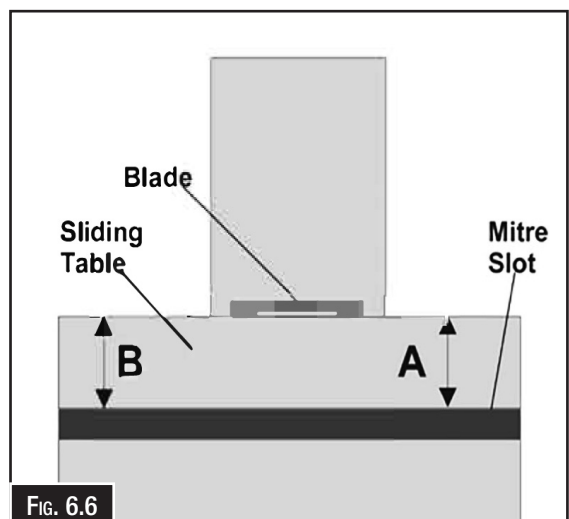

FIG. 6.6

To Adjust The Sliding Panel Parallel With The Main Blade (Cont.):

6. Move the other end of the sliding panel in front of the blade and measure the gap.

If the gap is the same on both sides, then the sliding panel is already parallel with the main blade.

If the gap on one side is different than the other, then continue with step 6.

7. Move the end of the sliding panel that needs to be adjusted in front of the blade.
8. Loosen the two hex head screws (C) and lightly tap the sliding carrier support to adjust the gap.
9. Repeat step 8 until the gap between your mark on the blade and the edge of the sliding panel is even at both ends.
10. Tighten the four hex head screws (C) and secure supports in place
11. Now tighten the two star-type screws that secure the sliding panel to the base.

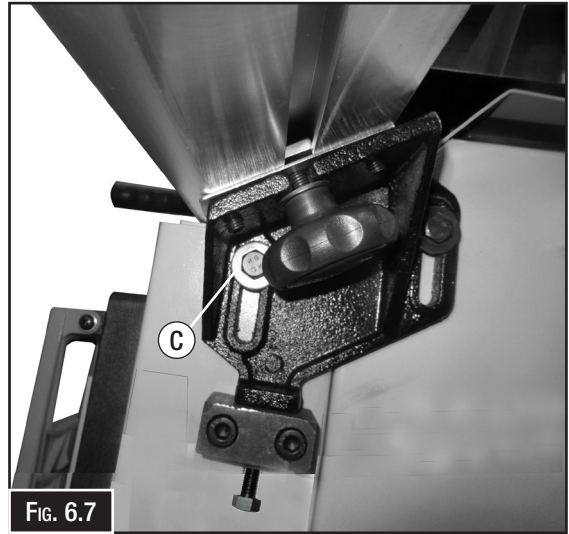

6.4 WIRING DIAGRAM

1~, Motor

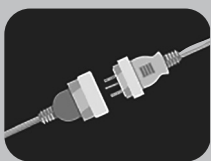
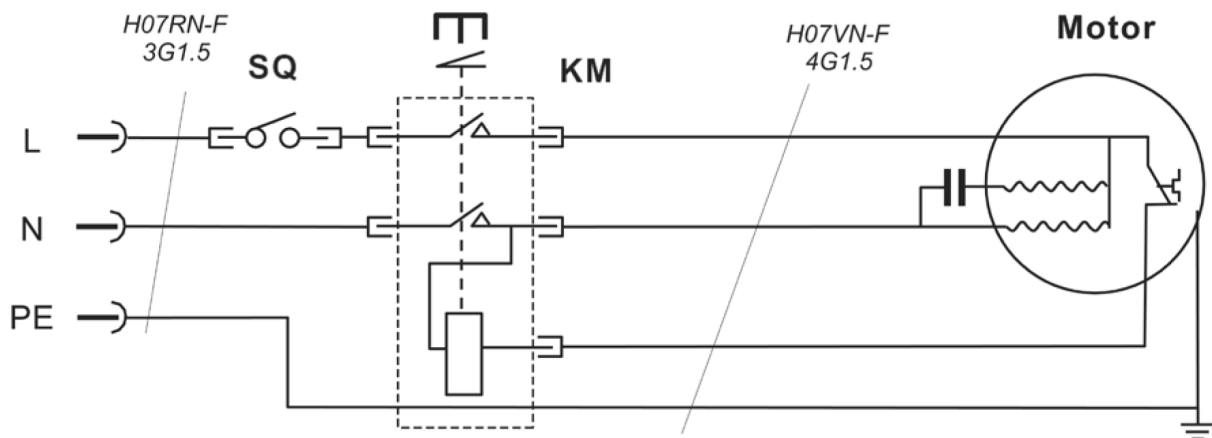

WARNING!
Always disconnect the power to the machine before doing any adjusting or maintenance to the machine.

6.5 TROUBLESHOOTING

Review the troubleshooting and procedures in this section if a problem develops with your machine. If you need replacement parts then follow the procedure in the beginning of the spare parts section or if additional help with a procedure is required, then contact your distributor.

Note: Make sure you have the model of the machine, serial number, and manufacture date before calling.

SYMPTOMS	POSSIBLE CAUSE	POSSIBLE SOLUTION
Saw does not start.	<ol style="list-style-type: none"> 1. Motor cord or wall cord is not plugged in. 2. Circuit fuse is blown. 3. Circuit breaker is tripped. 4. Cord or switch is damaged. 	<ol style="list-style-type: none"> 1. Plug in motor cord or wall cord. 2. Replace circuit fuse. 3. Reset circuit breaker. 4. Have the cord or switch replaced at your nearest Service Center.
Saw is noisy when running.	<ol style="list-style-type: none"> 1. Motor needs attention. 	<ol style="list-style-type: none"> 1. Have the motor checked at your nearest Service Center.
Motor is slow or weak	<ol style="list-style-type: none"> 1. Voltage from source is low. 2. Windings are burned out or open. 3. Start switch is defective. 4. Circuit is overloaded with appliances, lights, or other motors. 	<ol style="list-style-type: none"> 1. Request a voltage check from the power company. 2. Have the motor checked at your nearest Service Center. 3. Have the switch replaced. 4. Do not use other appliances or motors on the same circuit when using the saw.
Motor overheats.	<ol style="list-style-type: none"> 1. Starter switch is defective. 2. Voltage from source is low. 3. Dull blade. 4. Fuses / circuit breakers are wrong size or defective. 5. Feeding workpiece too rapidly. 	<ol style="list-style-type: none"> 1. Have the switch replaced. 2. Request a voltage check from the power company. 3. Replace the blade. 4. Replace fuses or circuit breakers. 5. Feed workpiece into blade slower.
Fuses or circuit breakers open frequently	<ol style="list-style-type: none"> 1. Motor is overloaded. 2. Fuses / circuit breakers are wrong size or defective. 3. Dull blade. 4. Start switch is defective. 	<ol style="list-style-type: none"> 1. Feed work more slowly. 2. Replace fuses or circuit breakers. 3. Replace the blade. 4. Have the switch replaced.
Saw vibrates excessively	<ol style="list-style-type: none"> 1. Blade is warped. 2. Belt is damaged. 3. Saw is not mounted securely. 4. Work surface is uneven. 	<ol style="list-style-type: none"> 1. Replace the blade. 2. Replace the belt. 3. Tighten all hardware. 4. Reposition on a flat surface. Adjust the levelling feet on legs
Start switch does not operate.	<ol style="list-style-type: none"> 1. Switch contacts are burned out. 2. Capacitor is defective 3. Connections are loose or damaged. 	<ol style="list-style-type: none"> 1. Have the switch replaced and request a voltage check from the power company. 2. Have the capacitor replaced. 3. Have the wiring checked and repaired
Hand wheels are hard to turn.	<ol style="list-style-type: none"> 1. Sawdust has collected on the mechanism inside saw. 	<ol style="list-style-type: none"> 1. Clean and lubricate the mechanism
Blade does not lower when turning height hand wheel.	<ol style="list-style-type: none"> 1. Blade lock handle is not fully released 	<ol style="list-style-type: none"> 1. Fully release the blade lock handle.
Cut binds, bums or stalls motor when ripping.	<ol style="list-style-type: none"> 1. Blade or teeth are dull. 2. Board is warped. 3. Rip fence is not parallel to the blade. 	<ol style="list-style-type: none"> 1. Sharpen or replace the blade. 2. Replace the board. 3. See Aligning the Rip Fence in the Assembly section.
Saw blade does not cut true at 90° or 45° positions.	<ol style="list-style-type: none"> 1. Indicators are not properly adjusted. 2. Positive stops inside base are not accurate. 	<ol style="list-style-type: none"> 1. Speak to your service centre. 2. Speak to your service centre.
Rip fence does not move smoothly	<ol style="list-style-type: none"> 1. Rip fence is not mounted correctly. 2. Rails are dirty or sticky. 	<ol style="list-style-type: none"> 1. Remove and reposition the rip fence. See Aligning Rip Fence and Front Rail in the Assembly section. 2. Clean and wax the rails.
Wood edges away from rip fence when ripping.	<ol style="list-style-type: none"> 1 Rip fence is misaligned. 	<ol style="list-style-type: none"> 1 See the Assembly section for Checking Rip Fence and Blade Alignment and Aligning Rip Fence and Front Rail procedures.

PANEL SAW PS-1810

Order Code: (W700)

The following section covers the spare parts diagrams and lists that were current at the time this manual was originally printed. Due to continuous improvements of the machine, changes may be made at anytime without notification.

HOW TO ORDER SPARE PARTS

1. Have your machines model number, serial number & date of manufacture on hand, these can be found on the specification plate mounted on the machine.
2. A scanned copy of your parts list/diagram with required spare part/s identified.

NOTE: SOME PARTS MAY ONLY BE AVAILABLE AS AN ASSEMBLY

3. Go to www.machineryhouse.com.au/contactus and fill out the inquiry form attaching a copy of scanned parts list.



WARNING!

*Electricity is dangerous and could cause death
All electrical work must be carried out by a qualified electrician.*



CAUTION!

It is impossible to cover all possible hazards Every workshop environment is different. These are designed as a guide to be used to compliment training and as a reminder to users prior to equipment use. Always consider safety first, as it applies to the individual working conditions.

PARTS LIST - A

ITEM	DESCRIPTION	ITEM	DESCRIPTION
A-1	HEX SCREW M8X20	A-22	COVER, SWITCH BOX
A-2	WASHER 8MM	A-23	PLASTIC PLATE
A-3	HEX NUT M8	A-24	STRAIN RELIEF
A-4	FRONT PANEL, SAW BASE	A-25	SWITCH BOX
A-5	PAN HEAD SCREW M6X12	A-26	EXTERNAL WASHER 4MM
A-6	WASHER 6MM	A-27	GROUND PLATE
A-7	DUST PORT	A-28	WASHER 4MM
A-8	RIVETED NUT	A-29	PAN HEAD SCREW M4X12
A-9	RIGHT PANEL, SAW BASE	A-30	HOLD SCREW, PUSH STICK
A-10	HEX NUT M6	A-31	PUSH STICK
A-11	REAR PANEL, SAW BASE	A-32	INTERNAL GUARD
A-12	LEFT PANEL, SAW BASE	A-33	MOUNT PLATE
A-13	RUBBER FEET	A-34	PAN HEAD SCREW M5X16
A-14	PAN HEAD SCREW M5X20	A-35	RUBBER SEAL
A-15	WASHER 5MM	A-36	ANGLE BRACKET
A-16	WIRE CLAMP	A-37	PAN HEAD SCREW M4X10
A-17	HEX NUT M5	A-38	ANGLE BRACKET
A-18	KNEE TOUCH PLATE	A-39	PAN HEAD SCREW M4X50
A-19	TAPING SCREW ST4.2X20	A-40	LIMIT SWITCH
A-20	SAW BASE FRAME	A-41	HEX NUT M4
A-21	MAIN SWITCH	A-42	ALLEN SCREW M6X12

NOTE: SOME INDIVIDUAL PARTS MAY ONLY BE AVAILABLE AS AN ASSEMBLY

DIAGRAM - B

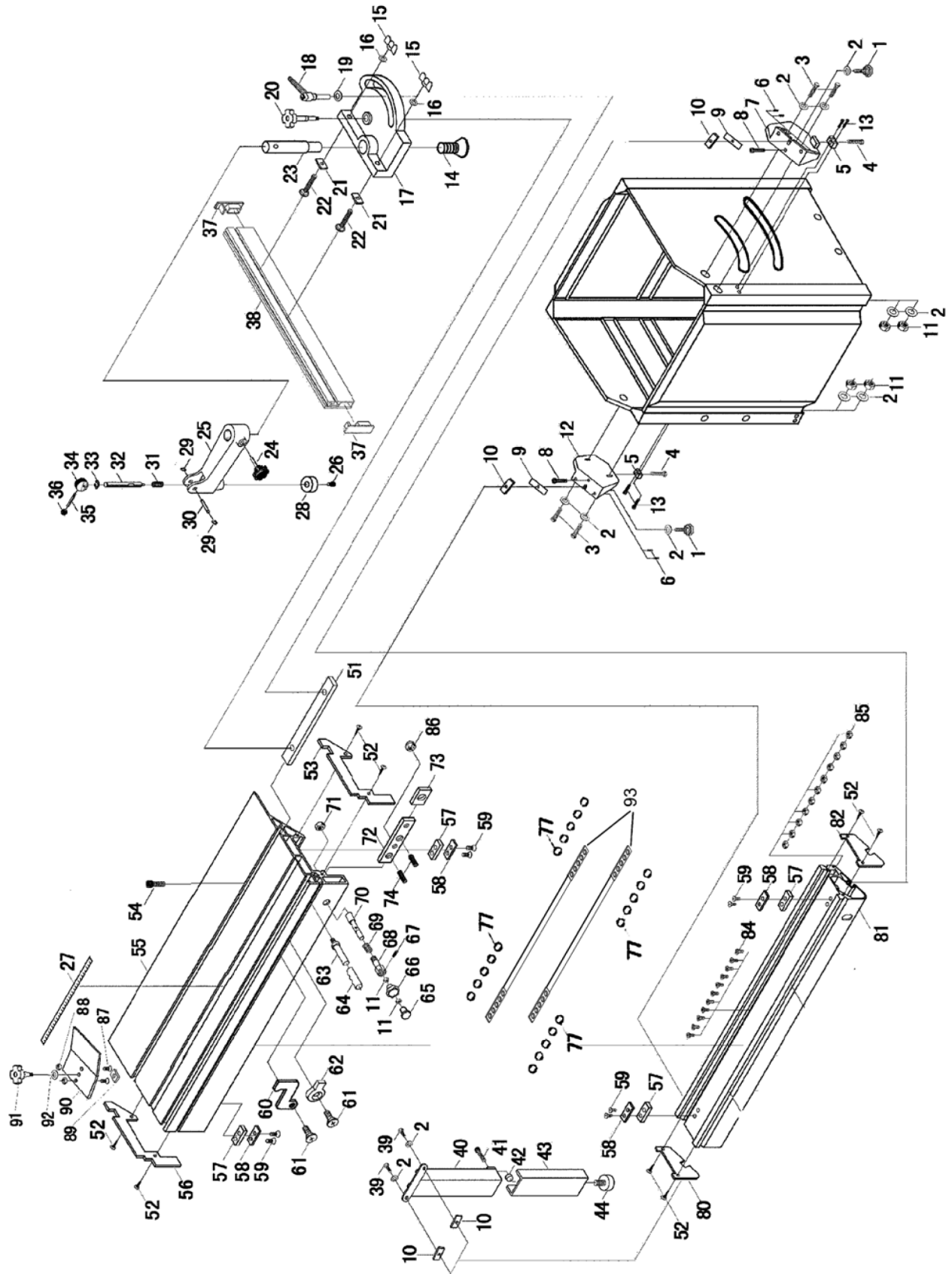

PARTS LIST - B

ITEM	DESCRIPTION	ITEM	DESCRIPTION
B-1	STAR-TYPE, LOCK HANDLE	B-43	LOWER SUPPORT
B-2	FLAT WASHER 8MM	B-44	ADJUSTABLE DISC
B-3	HEX SCREW M8X25	B-51	SCREW GUIDE
B-4	HEX SCREW M8X40	B-52	TAPING SCREW ST4,2X12
B-5	T-BASE, ADJUST	B-53	END CAP, SLIDING PANEL
B-6	SET SCREW M8X12	B-54	ALLEN SCREW M5X8
B-7	BRACKET, SLIDING CARRIER	B-55	SLIDING PANEL SET
B-8	STOP SCREW	B-56	END CAP, SLIDING PANEL
B-9	INSERT, SLIDING CARRIER	B-57	STOP PLATE
B-10	T-NUT, SLIDING CARRIER	B-58	STOP PLATE
B-11	HEX NUT M8	B-59	SUNK HEAD SCREW M6X18
B-12	BRACKET, SLIDING CARRIER	B-60	"Z" LOCK PLATE
B-13	ALLEN SCREW M8X32	B-61	SUNK HEAD SCREW M6X20
B-14	SUNK HEAD SCREW M8X25	B-62	ECCENTRIC CAM
B-15	WING NUT	B-63	PUSH HANDLE
B-16	WASHER 6MM	B-64	BUSH, PUSH HANDLE
B-17	MITRE GAUGE, HOLD DOWN	B-65	END CAP, KNOB
B-18	RATCHET LEVER	B-66	STAR-TYPE KNOB, LOCK PIN
B-19	FLAT WASHER 10MM	B-67	ROLL PIN 3X18
B-20	STAR-TYPE LOCK HANDLE	B-68	BUSH, LOCK PIN
B-21	T-BLOCK	B-69	SPRING, LOCK PIN
B-22	CARRIAGE BOLT M6X40	B-70	LOCK PIN
B-23	STUD, HOLD DOWN	B-71	HEX NUT M10
B-24	STAR-TYPE KNOB, HOLD DOWN	B-72	LOCK GUIDE
B-25	ARM, HOLD DOWN	B-73	T-NUT, PUSH HANDLE
B-26	ALLEN SCREW M5X16	B-74	SET SCREW M8X12
B-27	SCALE, SLIDING TABLE	B-77	BALL 1/2"
B-28	DISC, HOLD DOWN	B-80	END CAP, SLIDING RAIL
B-29	CIRCLE RING 8MM	B-81	SLIDING TABLE RAIL
B-30	PIN, HOLD DOWN	B-82	END CAP, SLIDING RAIL
B-31	SPRING, HOLD DOWN	B-84	SUNK HEAD SCREW M8X20
B-32	STUD, HOLD DOWN	B-85	LOCK NUT M8
B-33	CIRCLE RING 12MM	B-86	LOCK NUT M6
B-34	ECCENTRIC, HOLD DOWN	B-87	THREAD STUD
B-35	HANDLE, HOLD DOWN	B-88	HEX NUT M8
B-36	HANDLE KNOB, HOLD DOWN	B-89	T-BLOCK
B-37	END CAP, FENCE	B-90	EDGE SHOE
B-38	FENCE, MITRE GAUGE	B-91	STAR TYPE SCREW M8X20
B-39	HEX HEAD SCREW M8X16	B-92	WASHER 8MM
B-40	UPPER SUPPORT	B-93	BALL FRAME
B-41	ALLEN SCREW M8X25		
B-42	DISC, INSERT		

NOTE: SOME INDIVIDUAL PARTS MAY ONLY BE AVAILABLE AS AN ASSEMBLY

PARTS LIST - C

ITEM	DESCRIPTION	ITEM	DESCRIPTION
C-1	ARBOR NUT (LEFT)	C-61	SET SCREW M6X8
C-2	OUTER FLANGE	C-62	SET SCREW M6X6
C-3	SAW BLADE	C-63	PULLEY, MOTOR
C-4	V-BELT 680MM	C-64	HEX SCREW M8X25
C-5	PULLEY, BLADE	C-65	LOCK WASHER 8MM
C-6	FLAT KEY 5X5X20	C-66	ANGLE LOCK BLOCK
C-7	ARBOR SHAFT	C-67	ANGLE CRADLE
C-8	BEARING 6201-2RS	C-69	HEX NUT M12
C-9	ARBOR SHAFT SLEEVE	C-70	LOCK WASHER12MM
C-10	ARBOR SHAFT BUSH	C-72	LOCK BOLT, GUARD
C-12	MOUNT BLOCK, RIVING KNIFE	C-73	HEX SCREW M8X20
C-13	COLLAR STOP	C-76	FLAT WASHER 8MM
C-14	SET SCREW M8X12	C-77	STAR-TYPE SCREW M8X20
C-15	SPACER, ELEVATION GEAR	C-78	PAN HEAD SCREW M5X12
C-16	HEX SCREW M8X20	C-79	ANGLE BRACKET
C-17	WASHER 8MM	C-80	ANGLE POINTER
C-18	BLOCK PLATE	C-81	WASHER 4MM
C-19	RIVING KNIFE	C-82	SPRING WASHER 4MM
C-20	KNURLED NUT	C-83	PAN HEAD SCREW M4X10
C-21	CARRIAGE BOLT M10X60	C-85	CHIP HOUSE
C-22	SET SCREW M8X20	C-86	ALLEN SCREW M8X18
C-23	SET SCREW M8X20	C-87	HOSE CLAMP 100MM
C-24	HEX NUT M8	C-88	HEX SCREW M6X25
C-25	STOP SCREW	C-89	DUST HOSE DIA.100 X 800MM
C-26	ALLEN SCREW M10X30	C-92	ARBOR PIN
C-27	LOCK NUT M8	C-93	NUT M10
C-28	RIVING KNIFE BRACKET	C-94	ROLL PIN 4X20
C-29	CONNECTION ROD	C-95	SPACER, LOCK LEVER
C-30	SUNK HEAD SCREW M8X20	C-96	ALLEN SCREW M6X25
C-31	BUSH, CONNECTION ROD	C-97	SWING PLATE, LOCK LEVER
C-32	SUNK HEAD SCREW M8X30	C-98	BUSH, LOCK LEVER
C-33	HEX SCREW M6X65	C-99	LOCK LEVER, ELEVATION
C-34	KNURLED NUT FOR MOTOR BASE	C-100	HANDLE, LOCK LEVER
C-36	TAPING SCREW ST4.2X26	C-101	SPRING, LOCK LEVER
C-37	SET SCREW M6X10	C-102	TAPING SCREW ST4.2X10
C-38	HAND WHEEL, MAIN BLADE	C-103	BLADE GUARD, HALF
C-39	HANDLE	C-104	BLADE GUARD, HALF
C-40	PAN HEAD SCREW M6X16	C-105	SEGMENT, BLADE GUARD
C-42	WASHER 6MM	C-106	SEGMENT, BLADE GUARD
C-43	HOUSING, KNOB	C-107	LOCK WASHER 8MM
C-44	ANGLE CONNECTION KNOB	C-108	BUSH
C-45	ROLL PIN 4X28	C-109	SPRING PIN 6X12
C-46	ANGLE ADJUST THREAD	C-110	BRACKET. WORM GEAR
C-48	ELEVATION CONNECTION ROD	C-111	SHORT ELEVATION CONNECTION ROD
C-49	ELEVATION NAIL B	C-112	SHAFT. WORM GEAR
C-51	HEX NUT M6	C-113	FLAT KEY 5X12
C-52	ADJUSTING FRAME	C-114	HEX. SCREW M6X16
C-53	CIRCLE RING 24MM	C-115	HEX. NUT M6
C-54	KNUCKLE	C-116	WORM GEAR
C-55	THIN HEX NUT M12	C-117	HEX. SCREW M5X10
C-56	ELEVATION GEAR	C-118	SPRING WASHER 5MM
C-57	LOCK BLOCK	C-119	WASHER 5MM
C-58	MOTOR	C-120	CONNECTION ROD. MOTOR BASE
C-59	HEX SCREW M8X40	C-121	MOTOR BASE
C-60	FLAT KEY 8X7X50		

NOTE: SOME INDIVIDUAL PARTS MAY ONLY BE AVAILABLE AS AN ASSEMBLY-

DIAGRAM - D

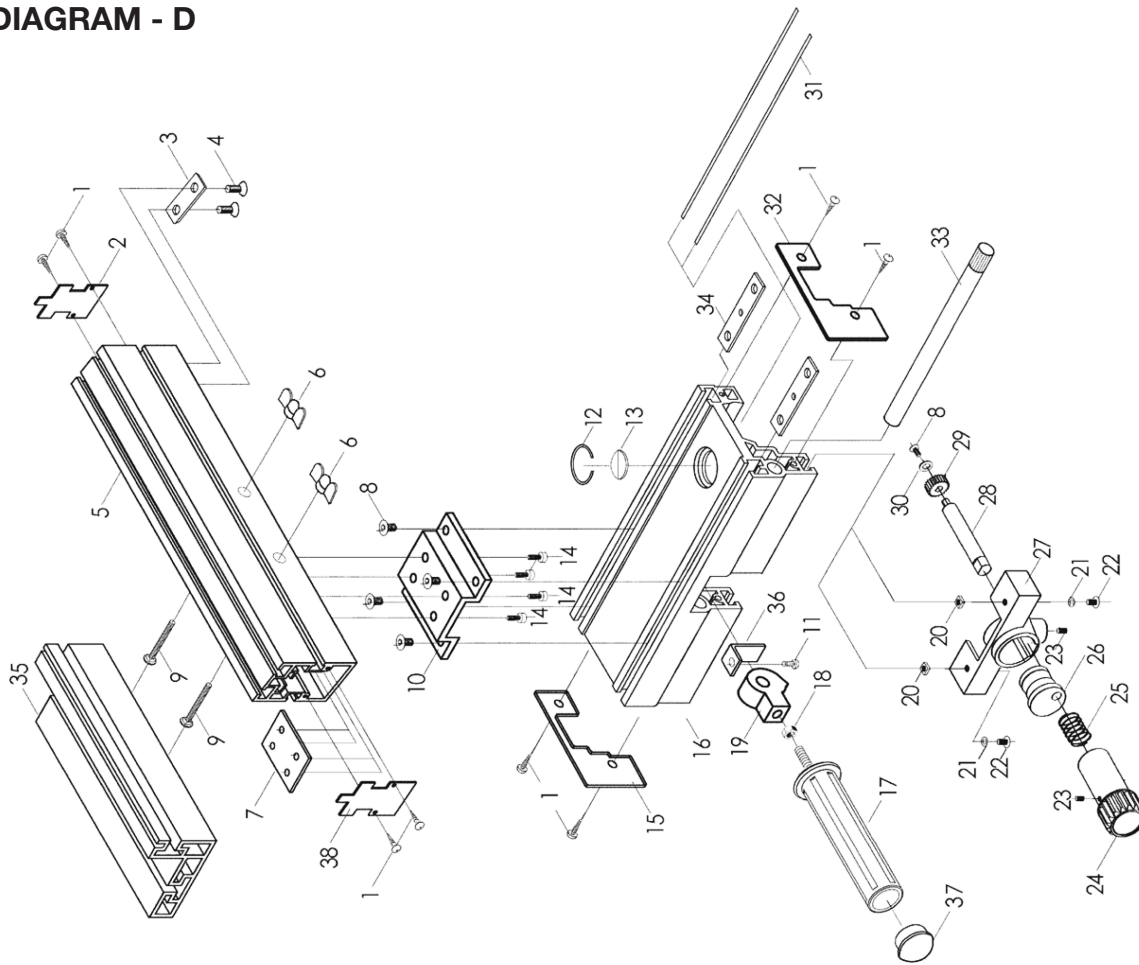

PARTS LIST - D

ITEM	DESCRIPTION	ITEM	DESCRIPTION
D-1	TAPING SCREW ST4.2X12	D-20	T-NUT MS
D-2	REAR PLATE, FENCE	D-21	WASHER 5MM
D-3	BOTTOM PLATE, FENCE	D-22	PAN HEAD SCREW M5X10
D-4	SUNK HEAD SCREW M5X8	D-23	SET SCREW M6X6
D-5	FENCE	D-24	FINE ADJUSTING HANDLE
D-6	WING NUT	D-25	COIL SPRING, FINE ADJUST
D-7	SCREW GUIDE	D-26	ECCENTRIC ARBOR
D-8	SUNK HEAD SCREW M6X12	D-27	FRAME, FINE ADJUST GEAR
D-9	CARRIAGE SCREW M6X70	D-28	GEAR ROD, FINE ADJUST
D-10	FENCE PLATE	D-29	CORE GEAR
D-11	PAN HEAD SCREW M4X10	D-30	WASHER 4MM
D-12	CIRCLE RING	D-31	RUBBER STICKER
D-13	LENSE	D-32	END CAP, FENCE CARRIER
D-14	ALLEN SCREW M6X16	D-33	LOCK SHAFT, FINE ADJUST
D-15	END CAP, FENCE CARRIER	D-34	SCREW GUIDE
D-16	FENCE CARRIER	D-35	FENCE "L" SHAPE
D-17	LOCK HANDLE, FENCE	D-36	LOCK PLATE
D-18	HEX NUT MB	D-37	END CAP, LOCK HANDLE
D-19	ECCENTRIC SHAFT	D-38	FRONT PLATE FENCE

NOTE: SOME INDIVIDUAL PARTS MAY ONLY BE AVAILABLE AS AN ASSEMBLY-

DIAGRAM - E

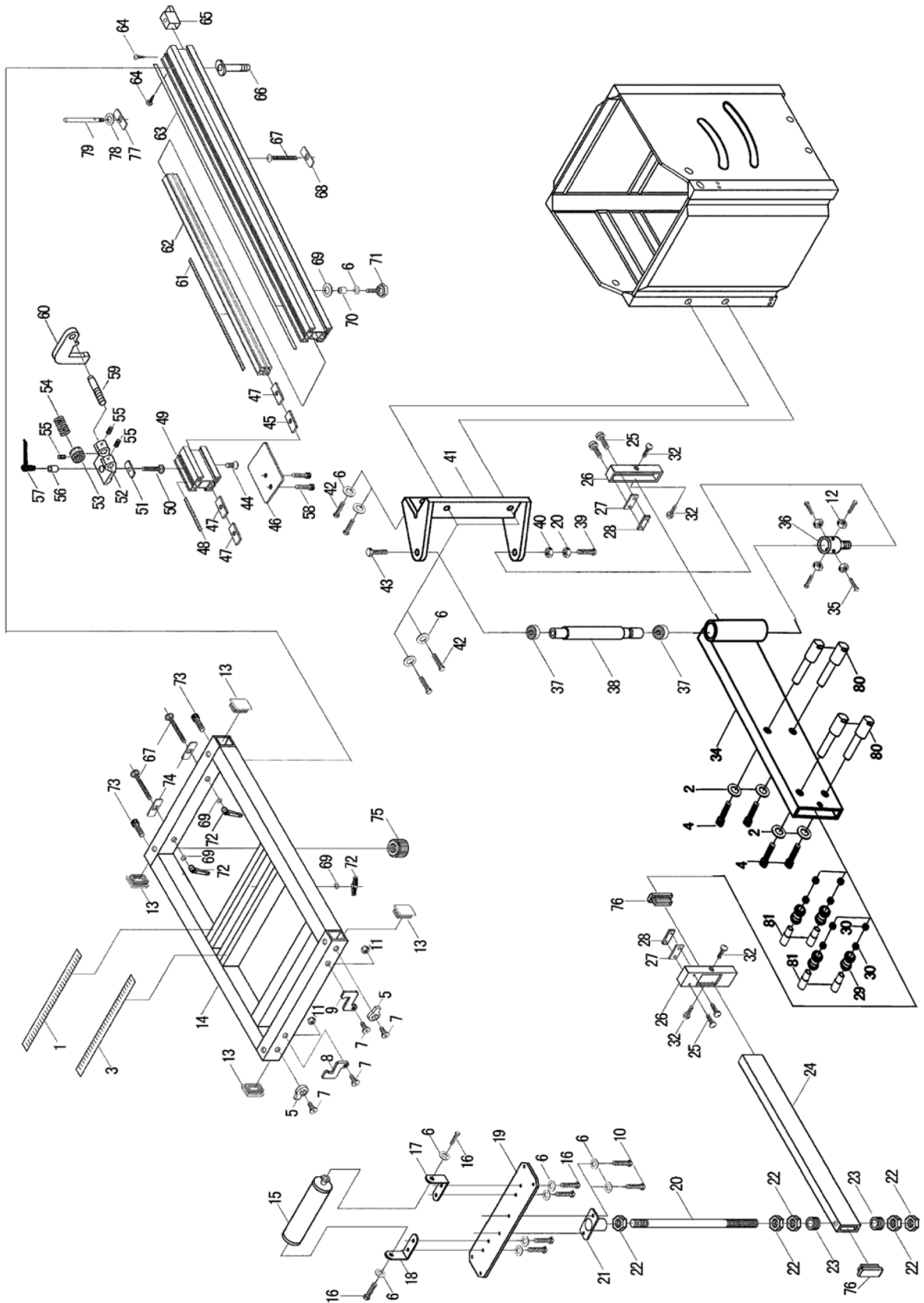

PARTS LIST - E

ITEM	DESCRIPTION	ITEM	DESCRIPTION
E-1	SCALE, CROSS CUT TABLE	E-41	SUPPORT, SWING ARM
E-2	WASHER 6MM	E-42	HEX SCREW M8X30
E-3	SCALE, CROSS CUT TABLE	E-43	HEX SCREW M10X25
E-4	ALLEN SCREW M6X12	E-44	SUNK HEAD SCREW M6X12
E-5	ECCENTRIC CAM	E-45	T-NUT, EXTENSION FENCE
E-6	WASHER 8MM	E-46	LOCK PLATE
E-7	SUNK HEAD SCREW M6X10	E-47	T-BLOCK
E-8	"Z" LOCK PLATE	E-48	SCALE
E-9	"Z" LOCK PLATE	E-49	END, EXTENSION FENCE
E-10	HEX SCREW M8X20	E-50	CARRIAGE BOLT M6X38
E-11	LOCK NUT M6	E-51	SCREW GUIDE
E-12	HEX NUT M6	E-52	FLIP STOP BASE
E-13	END CAP, CROSS CUT TABLE	E-53	KNURLED KNOB
E-14	CROSS CUT TABLE	E-54	SPRING, FLIP STOP
E-15	ROLLER	E-55	SET SCREW
E-16	HEX SCREW M8X12	E-56	SPACER , RATCHET LEVER
E-17	BRACKET, ROLLER	E-57	RATCHET LEVER, FLIP STOP
E-18	BRACKET, ROLLER	E-58	ALLEN SCREW M8X20
E-19	BASE, ROLLER	E-59	STUD, FLIP STOP
E-20	SUPPORT ROD, CROSS CUT TABLE	E-60	FLIP STOP
E-21	JOINT, SUPPORT	E-61	SCALE, EXTENSION FENCE
E-22	THIN HEX NUT M10	E-62	EXTENSION FENCE
E-23	BEARING 8104	E-63	SCALE, CROSS CUT FENCE
E-24	SWING ARM, EXTENSION	E-64	TAPING SCREW ST4.2 X12
E-25	PAN HEAD SCREW M5X12	E-65	END CAP, CROSS CUT FENCE
E-26	INSERT, SWING ARM	E-66	LOCK STUD, CROSS CUT FENCE
E-27	WOOLEN SHEET	E-67	CARRIAGE BOLT M8X70
E-28	BLOCK	E-68	T-BLOCK
E-29	ROLL	E-69	FLAT WASHER M8
E-30	BEARING 6101	E-70	SPACER, LOCK HANDLE
E-32	PAN HEAD SCREW M5X6	E-71	STAR-TYPE LOCK HANDLE
E-34	SWING ARM	E-72	WING NUT M8
E-35	HEX SCREW M6X35	E-73	STUD, CROSS CUT TABLE
E-36	STOP COLLAR	E-74	T-BLOCK
E-37	BEARING 6202	E-75	KNURLED KNOB, FENCE
E-38	SHAFT, SWING ARM	E-76	END CAP, SWING ARM
E-39	HEX SCREW M8X50	E-77	T-BLOCK, HOLD DOWN
E-40	THIN NUT M16	E-78	WASHER 12 MM
		E-79	STUD, HOLD DOWN
		E-80	ECCENTRIC SHAFT
		E-81	SLEEVE

NOTE: SOME INDIVIDUAL PARTS MAY ONLY BE AVAILABLE AS AN ASSEMBLY-

DIAGRAM - F

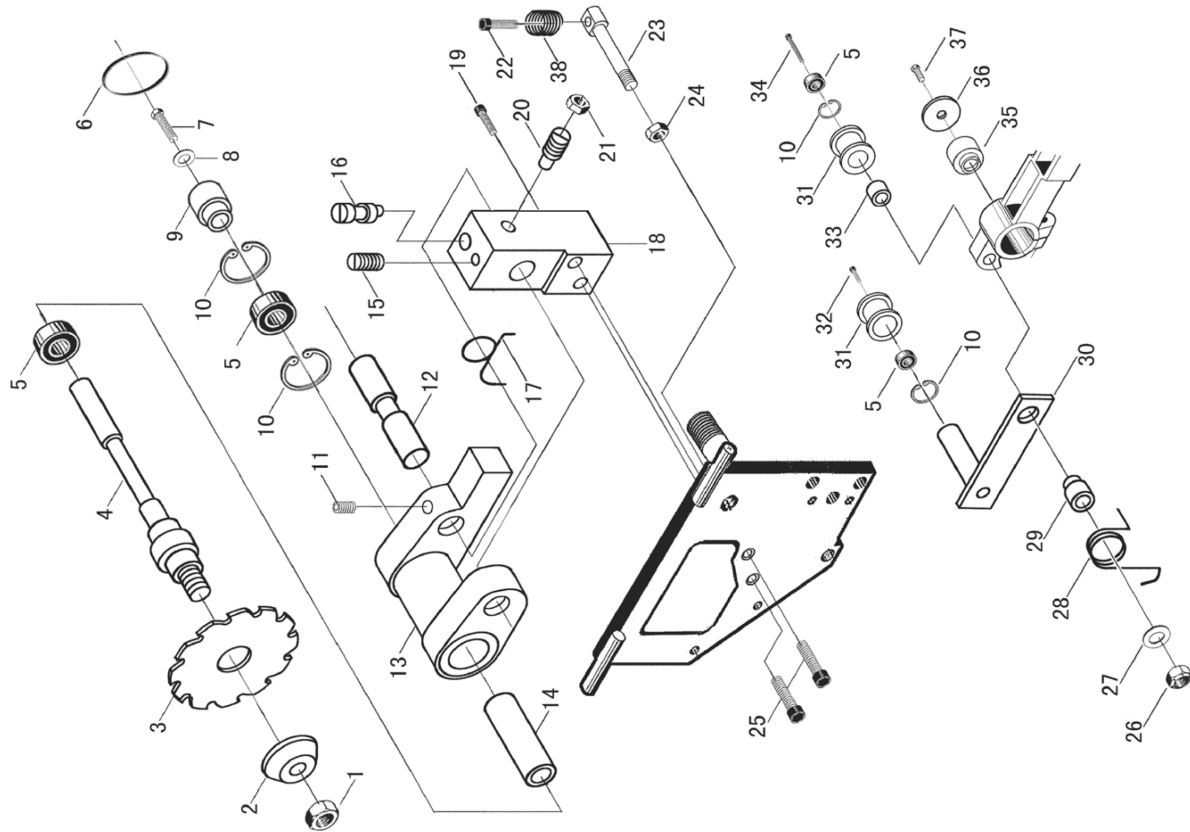

PARTS LIST - F

ITEM	DESCRIPTION	ITEM	DESCRIPTION
F-1	HEX NUT MB	F-19	ALLEN SCREW M6X12
F-2	OUTER FLANGE, SCORING BLADE	F-20	STOP SCREW
F-3	SCORING BLADE	F-21	HEX NUT M6
F-4	ARBOR, SCORING BLADE	F-23	ELEVATION, SCORING BLADE
F-5	BEARING 6100-RS	F-24	HEX NUT M10
F-6	FLAT BELT	F-25	ALLEN SCREW M6X18
F-7	HEX SCREW M6X12	F-26	LOCK NUT M10
F-8	WASHER 6MM	F-27	WASHER 10MM
F-9	PULLEY, SCORING BLADE	F-28	TENSION SPRING
F-10	CIRCLE RING 40MM	F-29	SPACER, TENSION SPRING
F-11	SET SCREW M6X6	F-30	TENSION PULLEY BRACKET
F-12	ADJUSTING SHAFT	F-31	TENSION PULLEY
F-13	HOUSING, ARBOR	F-33	SPACER, TENSION PULLEY
F-14	SPACER, SCORING BLADE	F-34	ALLEN SCREW M10X60
F-15	SET SCREW M8X18	F-35	PULLEY DRIVE
F-16	ECCENTRIC SHAFT	F-36	END CAP, PULLEY DRIVE
F-17	SPRING	F-37	HEX SCREW M6X8
F-18	BASE, ARBOR	F-38	COIL SPRING

NOTE: SOME INDIVIDUAL PARTS MAY ONLY BE AVAILABLE AS AN ASSEMBLY-

DIAGRAM - G

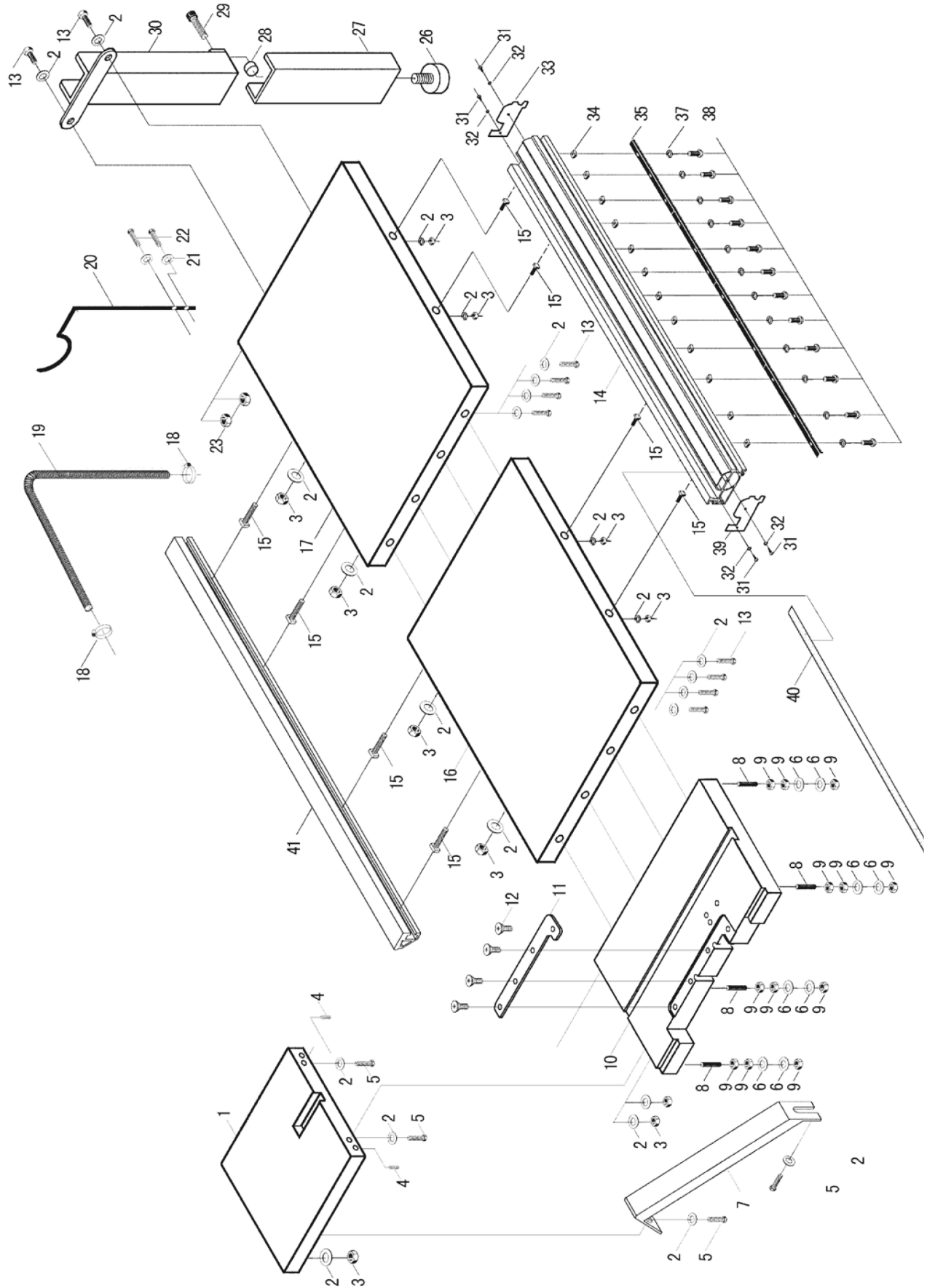

PARTS LIST - G

ITEM	DESCRIPTION	ITEM	DESCRIPTION
G-1	REAR EXTENSION TABLE	G-20	DUST HOSE SUPPORT
G-2	WASHER8MM	G-21	WASHER 6MM
G-3	HEX NUT M8	G-22	HEX SCREW M6X20
G-4	SET SCREW M6X12	G-23	HEX NUT M6
G-5	HEX SCREW M8X16	G-26	ADJUSTABLE DISC
G-6	FLAT WASHER 10MM	G-27	LOWER, SUPPORT
G-7	REA TABLE SUPPORT	G-28	DISC INSERT
G-8	SET SCREW M10X70	G-29	ALLEN SCREW M8X25
G-9	HEX NUT M10	G-30	UPPER, SUPPORT
G-10	MAJOR TABLE	G-31	TAPING SCREW ST4.2X12
G-11	TABLE INSERT	G-32	WASHER 4MM
G-12	SUNK HEAD SCREW M5X10	G-33	RIGHT END CAP, FRONT RAIL
G-13	HEX SCREW M8X20	G-34	T-NUT M5
G-14	FRONT RAIL	G-35	RACK, FENCE
G-15	SQUARE HEAD SCREW M8X25	G-37	LOCK WASHER 5MM
G-16	EXTENSION TABLE	G-38	PAN HEAD SCREW M5X8
G-17	STEEL EXTENSION TABLE	G-39	LEFT END CAP, FRONT RAIL
G-18	HOSE CLAMP 30MM	G-40	SCALE, RAIL
G-19	DUST HOSE 30MM DIA.X3240MM	G-41	REAR RAIL

NOTE: SOME INDIVIDUAL PARTS MAY ONLY BE AVAILABLE AS AN ASSEMBLY-

DIAGRAM - H

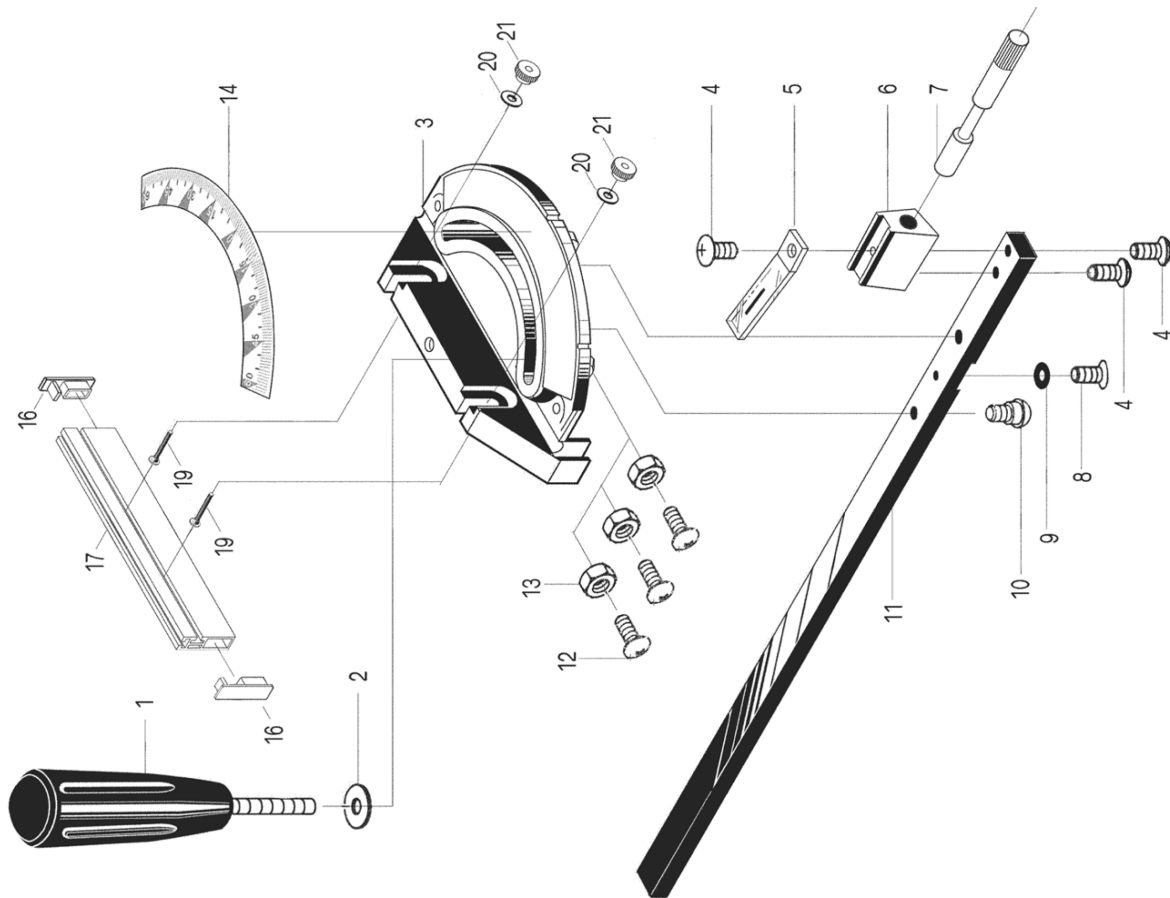

PARTS LIST - H

ITEM	DESCRIPTION	ITEM	DESCRIPTION
H-1	MITRE GAUGE KNOB	H-11	MITRE GAUGE ROD
H-2	WASHER 6MM	H-12	PAN HEAD SCREW M4X18
H-3	MITRE GAUGE BASE	H-13	HEX NUT M4
H-4	PAN HEAD SCREW M5X10	H-14	SCALE , GAUGE
H-5	INDICATOR GAUGE	H-16	END CAP, GAUGE FENCE
H-6	BLOCK INDICATOR	H-17	GAUGE FENCE
H-7	STOP PIN	H-19	CARRIAGE BOLT M6X32
H-8	SUNK HEAD SCREW M5X8	H-20	WASHER 6MM
H-9	ROLLER, GAUGE	H-21	KNURLED NUT
H-10	GUIDE PIN		

NOTE: SOME INDIVIDUAL PARTS MAY ONLY BE AVAILABLE AS AN ASSEMBLY-



ENVIRONMENT PROTECTION

Recycle unwanted materials instead of disposing of them as waste. All tools, accessories and packaging should be sorted, taken to a recycling centre and disposed of in a manner which is compatible with the environment. When the product becomes completely unserviceable and requires disposal, drain any fluids (if applicable) into approved containers and dispose of the product and fluids according to local regulations.

IMPORTED BY

HARE & FORBES
MACHINERYHOUSE

Australian Distributor

Hare & Forbes
Machineryhouse
Sydney - Melbourne
Adelaide - Brisbane - Perth

Ph: 1300 202 200
www.machineryhouse.com.au

MACHINERYHOUSE

New Zealand Distributor

Machineryhouse
Auckland
Christchurch

Ph: 0800 142 326
www.machineryhouse.co.nz